

TM80N04NF

N-Channel Enhancement Mosfet

<p>General Description</p> <ul style="list-style-type: none"> • Low $R_{DS(ON)}$ • RoHS and Halogen-Free Compliant <p>Applications</p> <ul style="list-style-type: none"> • Load switch • PWM 	<p>General Features</p> <p>$V_{DS} = 40V$ $I_D = 80A$</p> <p>$R_{DS(ON)} = 5.0m\Omega (typ.) @ V_{GS} = 10V$</p> <p>100% UIS Tested 100% R_g Tested</p> 
--	--

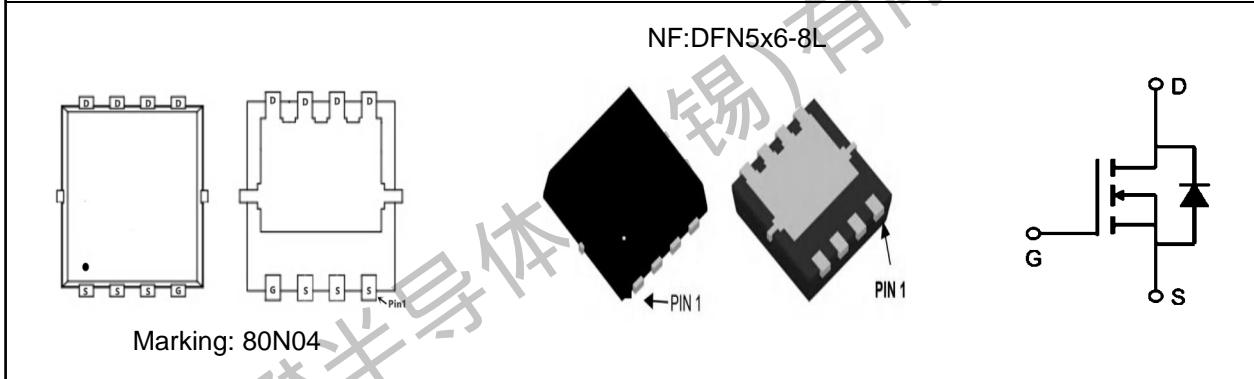

Absolute Maximum Ratings: ($T_A = 25^\circ C$ unless otherwise noted)

Symbol	Parameter	Rating	Unit	
Common Ratings				
V_{DSS}	Drain-Source Voltage	40	V	
V_{GSS}	Gate-Source Voltage	± 20		
T_J	Maximum Junction Temperature	150	$^\circ C$	
T_{STG}	Storage Temperature Range	-55 to 150		
I_S	Diode Continuous Forward Current	$T_C = 25^\circ C$	A	
I_D	Continuous Drain Current	$T_C = 25^\circ C$		80
		$T_C = 100^\circ C$		55
I_{DM}	Pulsed Drain Current	$T_C = 25^\circ C$	224	
P_D	Maximum Power Dissipation	$T_C = 25^\circ C$	54	W
		$T_C = 100^\circ C$	22	
$R_{\theta JC}$	Thermal Resistance-Junction to Case	Steady State	2.3	$^\circ C/W$
I_D	Continuous Drain Current	$T_A = 25^\circ C$	17.3	A
		$T_A = 70^\circ C$	13.8	
I_{DM}	Pulsed Drain Current	$T_A = 25^\circ C$	69	A
P_D	Maximum Power Dissipation	$T_A = 25^\circ C$	2.5	W
		$T_A = 70^\circ C$	1.6	
$R_{\theta JA}$	Thermal Resistance-Junction to Ambient	$t \leq 10s$	17	$^\circ C/W$
		Steady State	50	
I_{AS}	Avalanche Current, Single pulse	$L = 0.1mH$	32	A
E_{AS}	Avalanche Energy, Single pulse	$L = 0.1mH$	51	mJ

TM80N04NF

N-Channel Enhancement Mosfet

Electrical Characteristics ($T_J=25^{\circ}\text{C}$ unless otherwise specified)

Symbol	Parameter	Test Conditions	Min.	Typ.	Max.	Unit
Static Characteristics						
BV_{DSS}	Drain-Source Breakdown Voltage	$V_{GS}=0V, I_{DS}=250\mu A$	40	-	-	V
I_{DSS}	Zero Gate Voltage Drain Current	$V_{DS}=32V, V_{GS}=0V$ $T_J=85^{\circ}\text{C}$	-	-	1	μA
			-	-	30	
$V_{GS(th)}$	Gate Threshold Voltage	$V_{DS}=V_{GS}, I_{DS}=250\mu A$	1.2	1.6	2.0	V
I_{GSS}	Gate Leakage Current	$V_{GS}=\pm 20V, V_{DS}=0V$	-	-	± 100	nA
$R_{DS(ON)}$	Drain-Source On-state Resistance	$V_{GS}=10V, I_{DS}=20A$	-	5	5.8	m Ω
		$V_{GS}=4.5V, I_{DS}=15A$	-	6.2	7.8	
Gfs	Forward Transconductance	$V_{DS}=5V, I_{DS}=20A$	-	31	-	S
Diode Characteristics						
V_{SD}	Diode Forward Voltage	$I_{SD}=20A, V_{GS}=0V$	-	0.75	1.1	V
t_{rr}	Reverse Recovery Time	$I_{SD}=20A, dI_{SD}/dt=100A/\mu s$	-	28	-	ns
t_a	Charge Time		-	17	-	
t_b	Discharge Time		-	12	-	
Q_{rr}	Reverse Recovery Charge		-	20	-	
Dynamic Characteristics ^f						
R_G	Gate Resistance	$V_{GS}=0V, V_{DS}=0V, F=1\text{MHz}$	-	1	2	Ω
C_{iss}	Input Capacitance	$V_{GS}=0V, V_{DS}=20V,$ Frequency=1.0MHz	-	1645	2139	pF
C_{oss}	Output Capacitance		-	385	-	
C_{rss}	Reverse Transfer Capacitance		-	55	-	
$t_{d(ON)}$	Turn-on Delay Time		-	14.3	26	
t_r	Turn-on Rise Time	$V_{DD}=20V, R_L=20\Omega,$ $I_{DS}=1A, V_{GEN}=10V,$ $R_G=6\Omega$	-	7.7	14	ns
$t_{d(OFF)}$	Turn-off Delay Time		-	32.6	59	
t_f	Turn-off Fall Time		-	26.6	48	
Gate Charge Characteristics ^f						
Q_g	Total Gate Charge	$V_{DS}=20V, V_{GS}=10V,$ $I_{DS}=20A$	-	24.8	34.7	nC
Q_g	Total Gate Charge	$V_{DS}=20V, V_{GS}=4.5V,$ $I_{DS}=20A$	-	11.5	-	
Q_{gth}	Threshold Gate Charge		-	3	-	
Q_{gs}	Gate-Source Charge		-	5.2	-	
Q_{gd}	Gate-Drain Charge		-	2.6	-	



TM80N04NF

N-Channel Enhancement Mosfet

Typical Characteristics

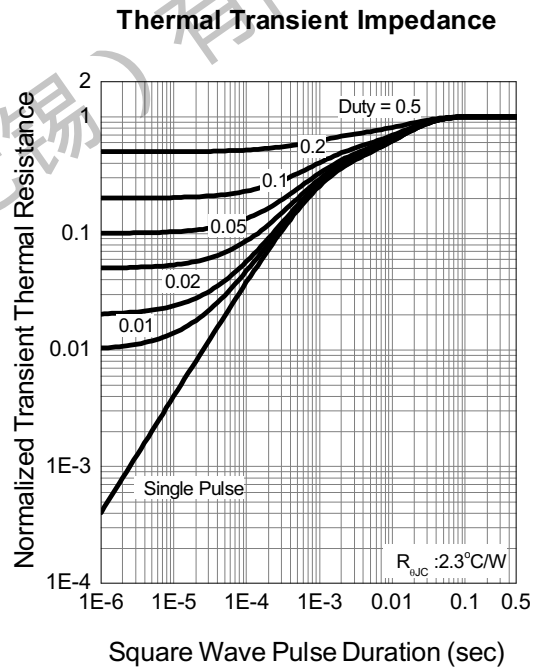
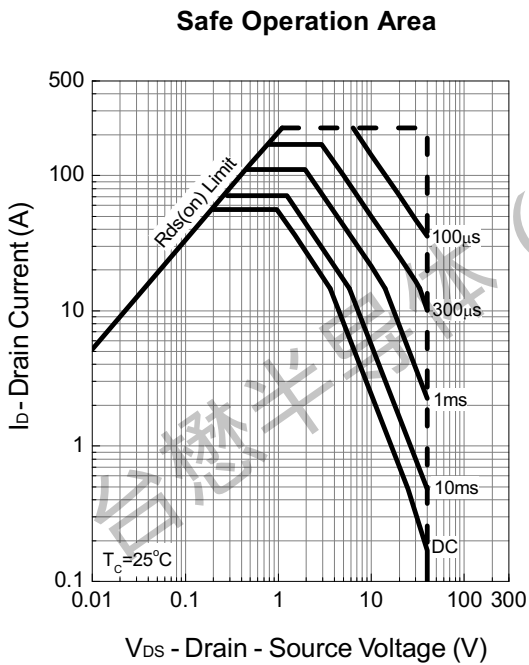
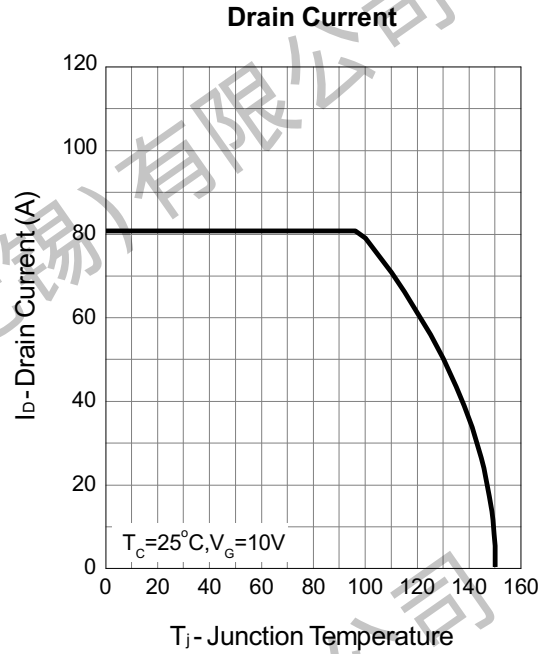
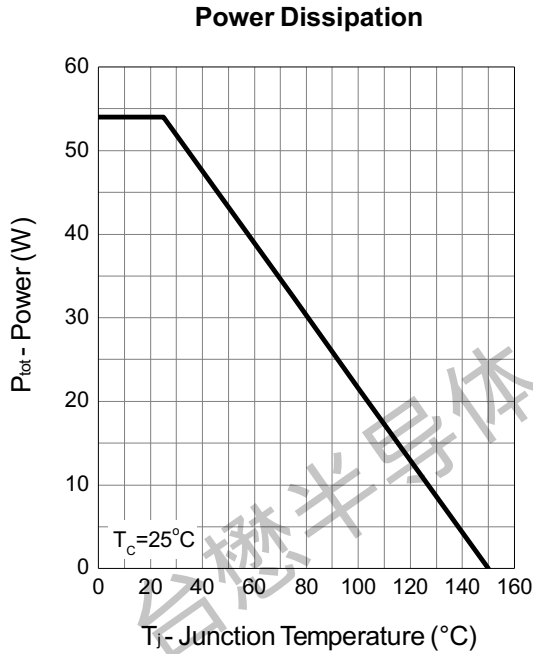



TM80N04NF

N-Channel Enhancement Mosfet

Safe Operation Area

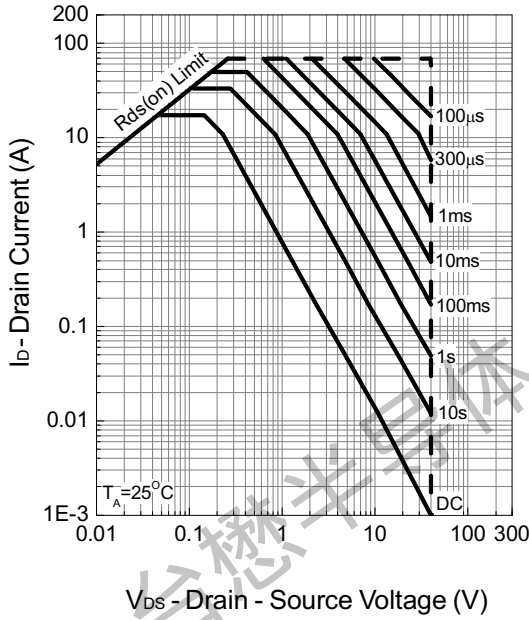

Thermal Transient Impedance

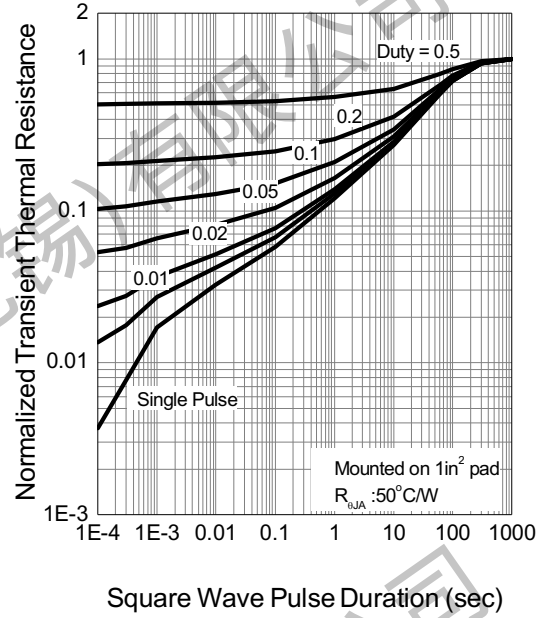

Output Characteristics

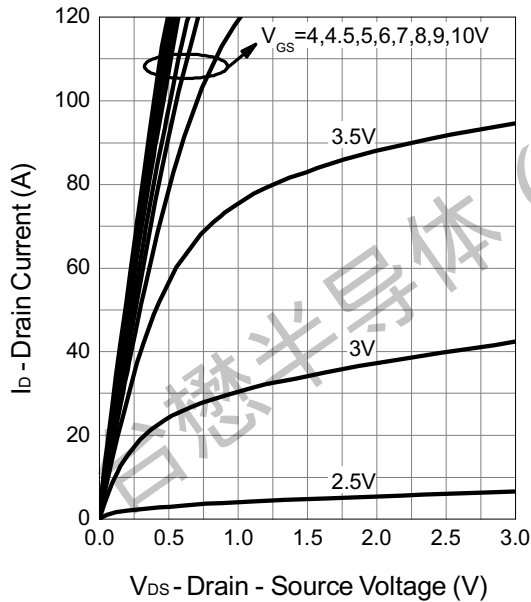

Drain-Source On Resistance

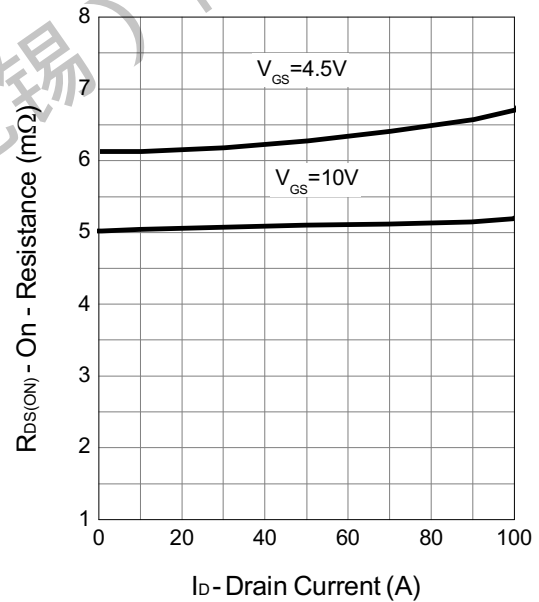



TM80N04NF

N-Channel Enhancement Mosfet

Gate-Source On Resistance

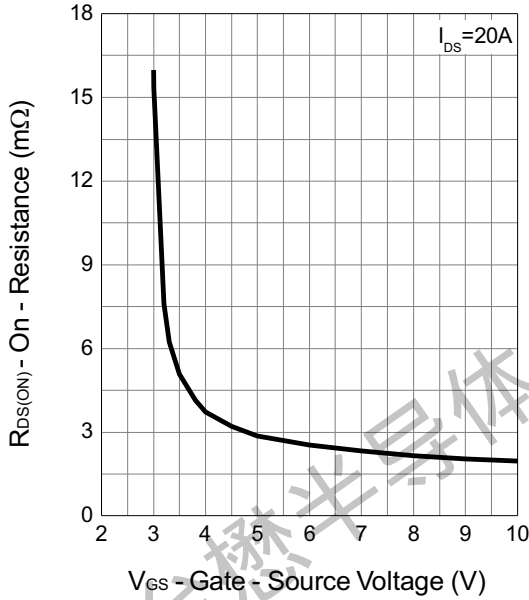

Gate Threshold Voltage

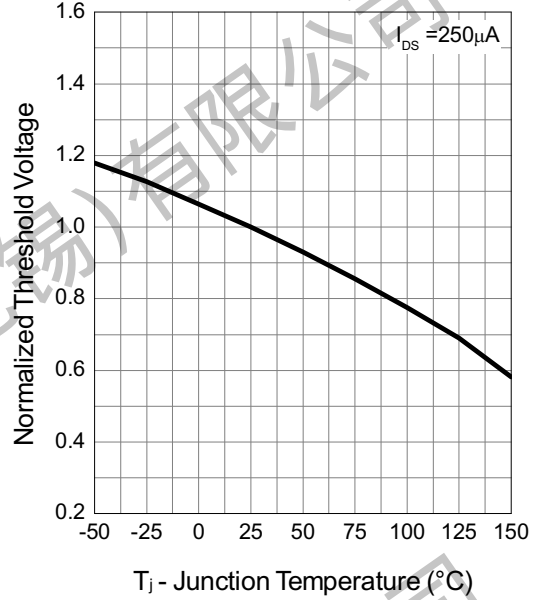

Drain-Source On Resistance

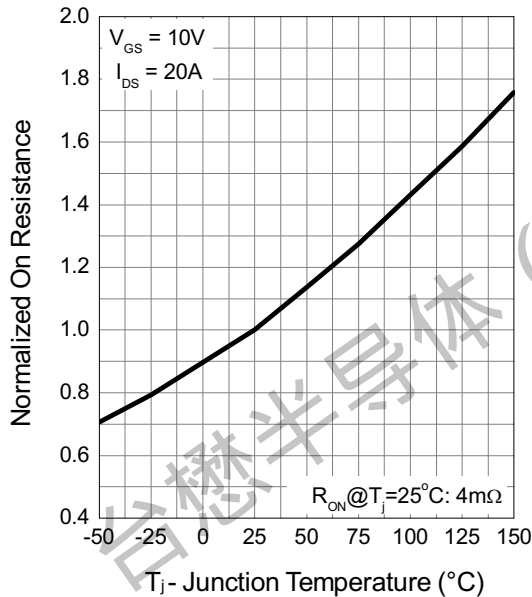

Source-Drain Diode Forward

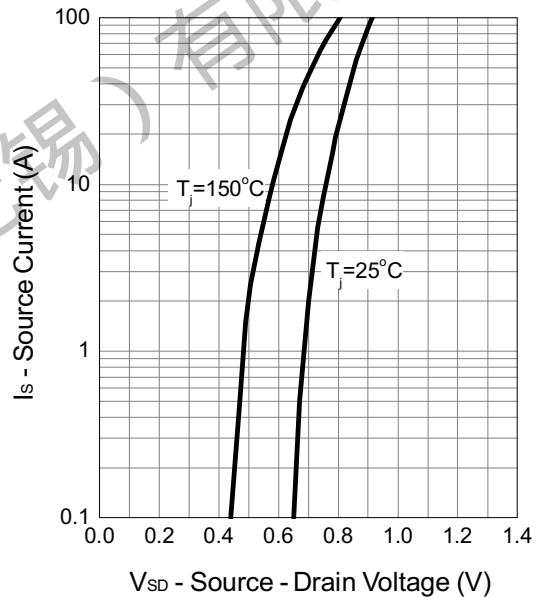



TM80N04NF

N-Channel Enhancement Mosfet

Capacitance

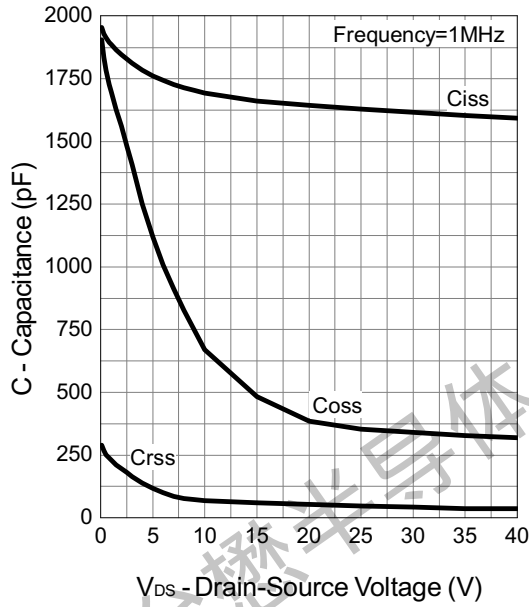

Gate Charge

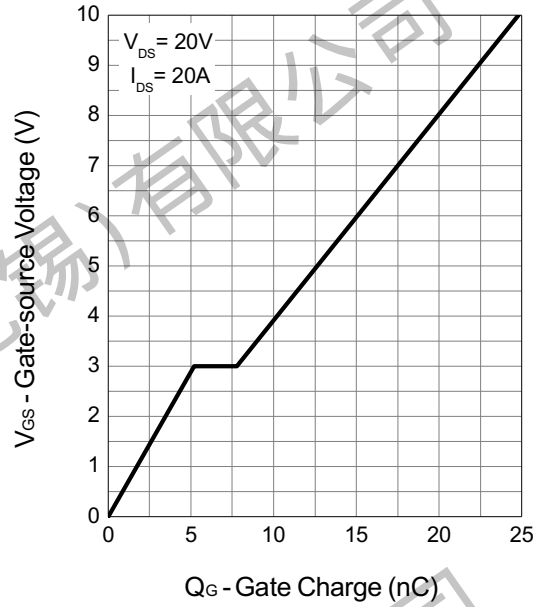

Transfer Characteristics

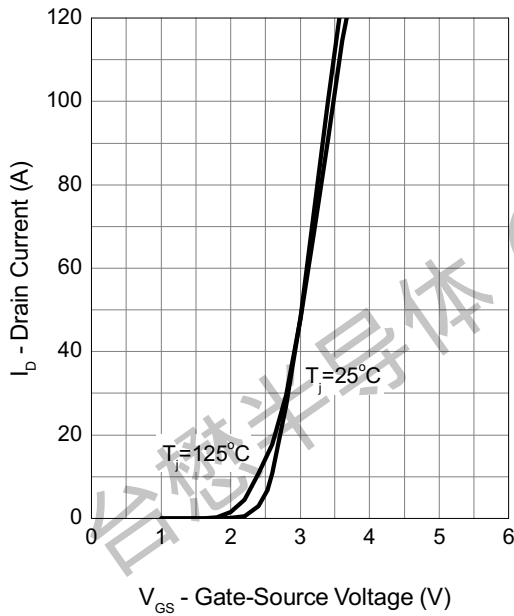

TM80N04NF

N-Channel Enhancement Mosfet

Package Mechanical Data:DFN5x6-8L

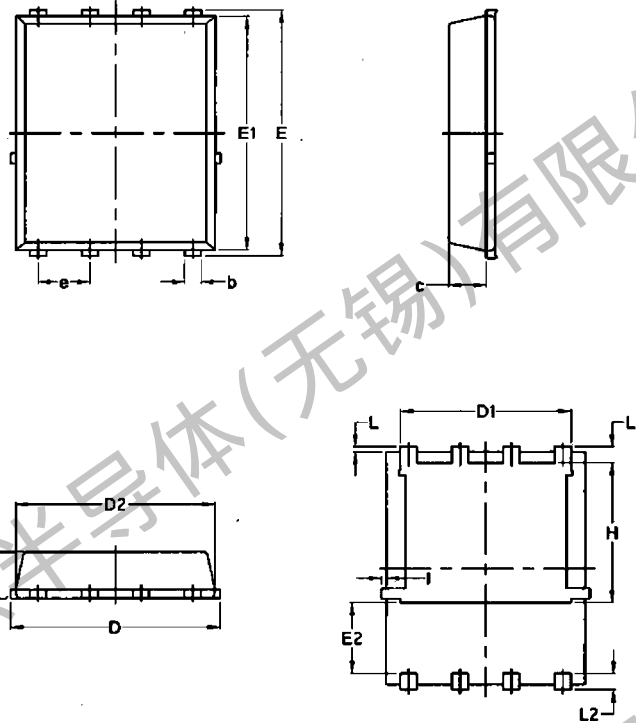

Symbol	Common			
	mm		Inch	
	Min	Max	Min	Max
A	1.03	1.17	0.0406	0.0461
b	0.34	0.48	0.0134	0.0189
c	0.824	0.0970	0.0324	0.082
D	4.80	5.40	0.1890	0.2126
D1	4.11	4.31	0.1618	0.1697
D2	4.80	5.00	0.1890	0.1969
E	5.95	6.15	0.2343	0.2421
E1	5.65	5.85	0.2224	0.2303
E2	1.60	/	0.0630	/
e	1.27 BSC		0.05 BSC	
L	0.05	0.25	0.0020	0.0098
L1	0.38	0.50	0.0150	0.0197
L2	0.38	0.50	0.0150	0.0197
H	3.30	3.50	0.1299	0.1378
l	/	0.18	/	0.0070

TM80N04NF

N-Channel Enhancement Mosfet

PDFN5x6-8L Embossed Carrier Tape

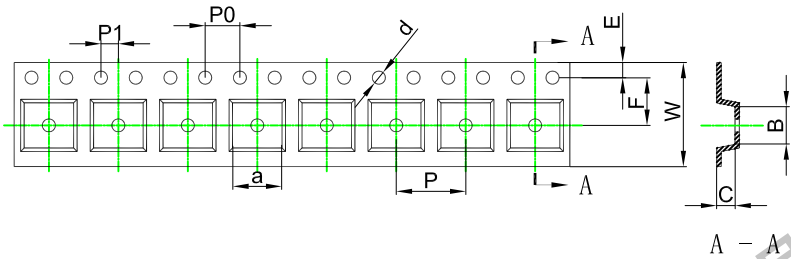

Packaging Description:

SOP-8L parts are shipped in tape. The carrier tape is made from a dissipative (carbon filled) polycarbonate resin. The cover tape is a multilayer film (Heat Activated Adhesive in nature) primarily composed of polyester film, adhesive layer, sealant, and anti-static sprayed agent. These reeled parts in standard option are shipped with 2,500 units per 13" or 33cm diameter reel. The reels are clear in color and is made of polystyrene plastic (anti-static coated).
ALL DIM IN mm

Dimensions are in millimeter										
Pkg type	a	B	C	d	E	F	P0	P	P1	W
PDFN5x6-8L	6.40	5.40	2.10	Ø1.50	1.75	5.50	4.00	8.00	2.00	12.00

PDFN5x6-8L Tape Leader and Trailer

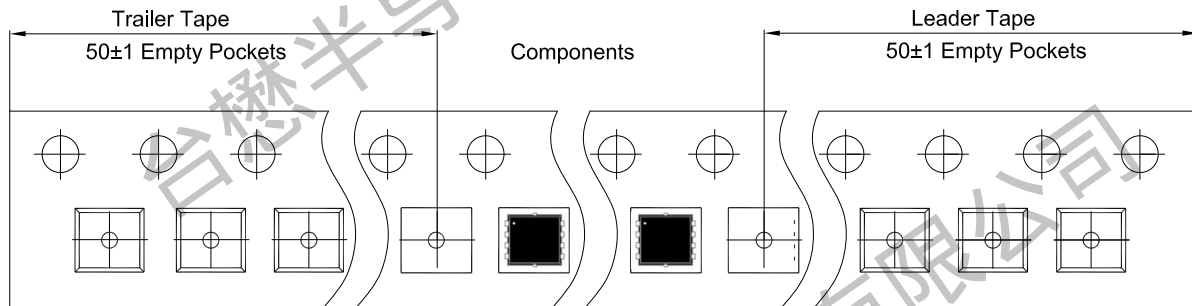

PDFN5x6-8L Reel

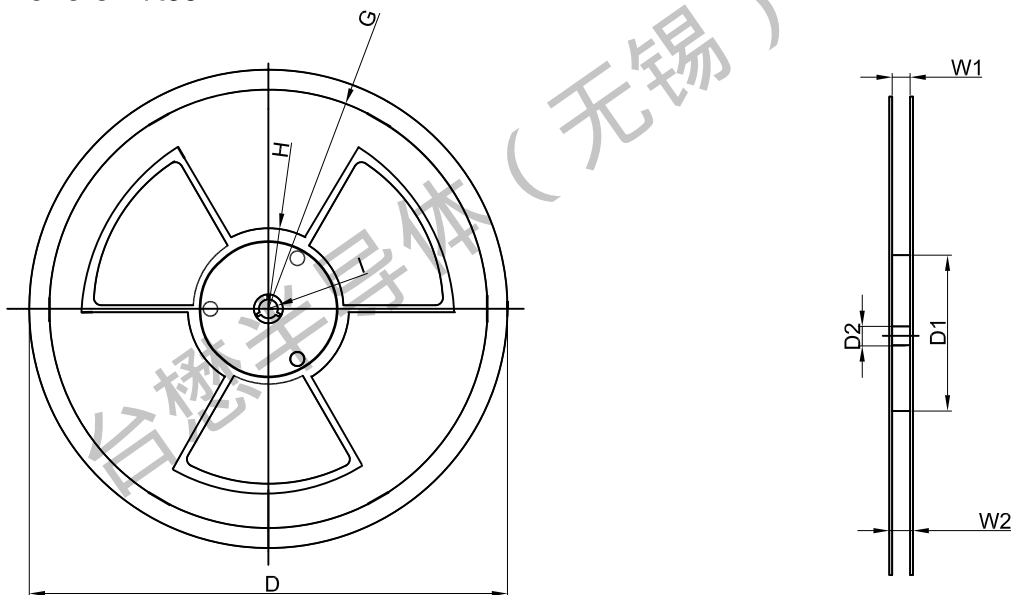

Dimensions are in millimeter								
Reel Option	D	D1	D2	G	H	I	W1	W2
13"Dia	Ø330.00	100.00	13.00	R135.00	R55.00	R6.50	12.00	14.00

REEL	Reel Size	Box	Box Size(mm)	Carton	Carton Size(mm)	G.W.(kg)
5,000 pcs	13 inch	10,000 pcs	370×355×52	50,000 pcs	400×360×368	



Important Notices and Disclaimers

- Tritech-MOS Technology Corp. reserves the right to change this document, its products, and specifications at any time without prior notice.
- Before final design, purchase, or use, customers should obtain and confirm the latest product information and specifications.
- Tritech-MOS Technology Corp. makes no warranties, representations or warranties regarding the suitability of its products for any specific purpose, and Tritech-MOS Technology Corp. does not assume any responsibility for application assistance or customer product design.
- Tritech-MOS Technology Corp. does not guarantee or assume any responsibility for the purchase or use of any unexpected or unauthorized products.
- Any intellectual property rights of Tritech-MOS Technology Corp. are not licensed through implicate or other means.
- Products of Tritech-MOS Technology Corp. are not included as critical components in life support equipment or systems without explicit written approval from Tritech-MOS Technology Corp.

Revision history:

Date	Rev	Description	Page
2023.04.17	23.04	Original	