



**TM60N06HAD**

**N-Channel Enhancement Mosfet**

<p><b>General Description</b></p> <ul style="list-style-type: none"> <li>• Low <math>R_{DS(ON)}</math></li> <li>• RoHS and Halogen-Free Compliant</li> </ul> <p><b>Applications</b></p> <ul style="list-style-type: none"> <li>• Load switch</li> <li>• PWM</li> </ul>	<p><b>General Features</b></p> <p><math>V_{DS} = 60V</math>   <math>I_D = 60A</math></p> <p><math>R_{DS(ON)} = 8m\Omega</math> (typ.) @ <math>V_{GS} = 10V</math></p> <p>100% UIS Tested 100% <math>R_g</math> Tested</p> 
------------------------------------------------------------------------------------------------------------------------------------------------------------------------------------------------------------------------------------------------------------------------	-------------------------------------------------------------------------------------------------------------------------------------------------------------------------------------------------------------------------------------------------------------------------------------------------------------------

**D:TO-252-3L**

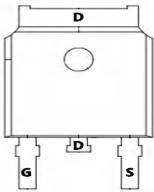
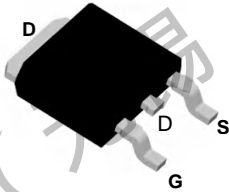
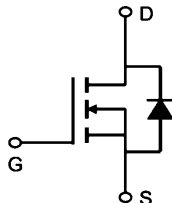
Marking: 60N06H

**Absolute Maximum Ratings** ( $T_C = 25^\circ C$  Unless Otherwise Noted)

Symbol	Parameter	Rating	Units
$V_{DS}$	Drain-Source Voltage	60	V
$V_{GS}$	Gate-Source Voltage	$\pm 25$	V
$I_D @ T_C = 25^\circ C$	Continuous Drain Current, $V_{GS} @ 10V$	60	A
$I_D @ T_C = 100^\circ C$	Continuous Drain Current, $V_{GS} @ 10V$	36	A
$I_{DM}$	Pulsed Drain Current	220	A
EAS	Single Pulse Avalanche Energy	59	mJ
$P_D @ T_C = 25^\circ C$	Total Power Dissipation	63	W
$T_{STG}$	Storage Temperature Range	-55 to 175	$^\circ C$
$T_J$	Operating Junction Temperature Range	-55 to 175	$^\circ C$

**Thermal Data**

Symbol	Parameter	Typ.	Max.	Unit
$R_{\theta JA}$	Thermal Resistance Junction-ambient	---	62	$^\circ C/W$
$R_{\theta JC}$	Thermal Resistance Junction-Case	---	2.4	$^\circ C/W$



**TM60N06HAD**

**N-Channel Enhancement Mosfet**

**Electrical Characteristics** (T<sub>J</sub>=25°C unless otherwise specified)

Symbol	Parameter	Conditions	Min	Typ	Max	Units
<b>Off Characteristics</b>						
<b>BV<sub>DSS</sub></b>	Drain-Source Breakdown Voltage	V <sub>GS</sub> =0V, I <sub>D</sub> =250 μ A	60	---	---	V
<b>I<sub>DSS</sub></b>	Zero Gate Voltage Drain Current	V <sub>GS</sub> =0V, V <sub>DS</sub> =60V	---	---	1	μ A
<b>I<sub>GSS</sub></b>	Gate-Source Leakage Current	V <sub>GS</sub> =± 25V, V <sub>DS</sub> =0V	---	---	± 100	nA
<b>On Characteristics</b>						
<b>V<sub>GS(th)</sub></b>	GATE-Source Threshold Voltage	V <sub>GS</sub> =V <sub>DS</sub> , I <sub>D</sub> =250 μ A	2	3	4	V
<b>R<sub>DS(on)</sub></b>	Drain-Source On Resistance <sup>note3</sup>	V <sub>GS</sub> =10V, I <sub>D</sub> =30A	---	8	12	m Ω
<b>Dynamic Characteristics</b>						
<b>C<sub>iss</sub></b>	Input Capacitance	V <sub>DS</sub> =25V, V <sub>GS</sub> =0V, f=1MHz	---	2045	---	pF
<b>C<sub>oss</sub></b>	Output Capacitance		---	170	---	
<b>C<sub>rss</sub></b>	Reverse Transfer Capacitance		---	151	---	
<b>Switching Characteristics</b>						
<b>t<sub>d(on)</sub></b>	Turn-On Delay Time	V <sub>GS</sub> =10V, V <sub>DS</sub> =30V, R <sub>L</sub> =1.5Ω, R <sub>GEN</sub> =3Ω	---	10	---	ns
<b>t<sub>r</sub></b>	Rise Time		---	8	---	ns
<b>t<sub>d(off)</sub></b>	Turn-Off Delay Time		---	18	---	ns
<b>t<sub>f</sub></b>	Fall Time		---	5	---	ns
<b>Q<sub>g</sub></b>	Total Gate Charge	V <sub>GS</sub> =10V, V <sub>DS</sub> =30V, I <sub>D</sub> =20A	---	16	---	nC
<b>Q<sub>gs</sub></b>	Gate-Source Charge		---	5.6	---	nC
<b>Q<sub>gd</sub></b>	Gate-Drain "Miller" Charge		---	3.6	---	nC
<b>Drain-Source Diode Characteristics</b>						
<b>I<sub>S</sub></b>	Maximum Continuous Drain to Source Diode Forward Current		---	---	60	A
<b>I<sub>SM</sub></b>	Maximum Pulsed Drain to Source Diode Forward Current		---	---	220	A
<b>V<sub>SD</sub></b>	Source-Drain Diode Forward Voltage	V <sub>GS</sub> =0V, I <sub>S</sub> =30A	---	---	1.2	V
<b>trr</b>	Body Diode Reverse Recovery Time	I <sub>F</sub> =20A, dI/dt=50A/ μ s	---	18	---	ns
<b>Qrr</b>	Body Diode Reverse Recovery Charge	I <sub>F</sub> =20A, dI/dt=50A/ μ s	---	58	---	nc

TM60N06HAD

N-Channel Enhancement Mosfet

Typical Characteristics: ( $T_A=25^\circ\text{C}$  unless otherwise noted)

Figure 1: Output Characteristics

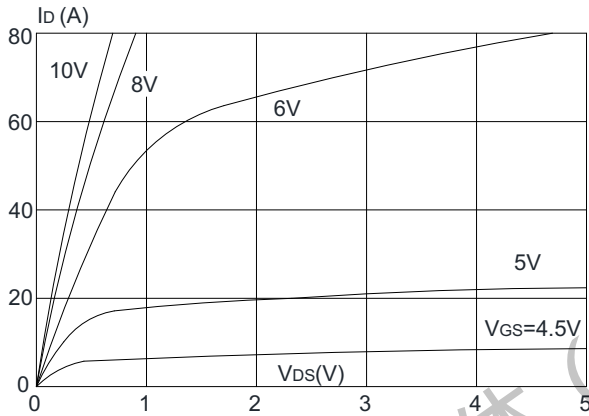

Figure 2: Typical Transfer Characteristics

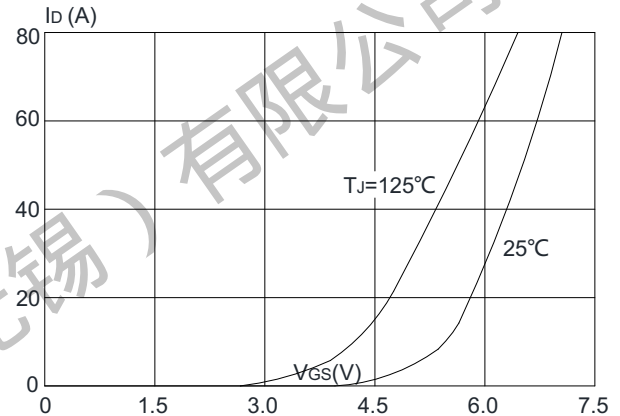

Figure 3: On-resistance vs. Drain Current



Figure 4: Body Diode Characteristics

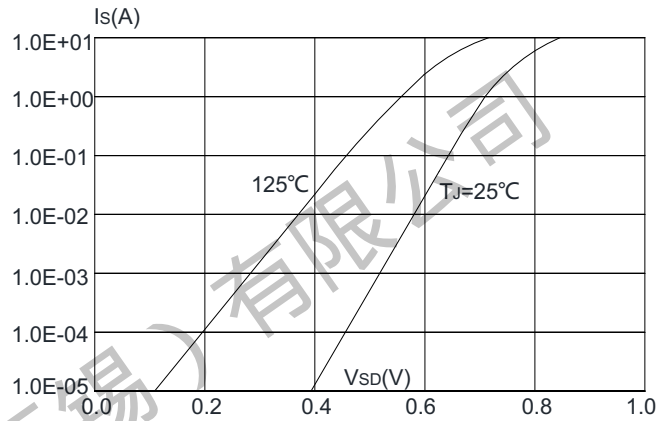

Figure 5: Gate Charge Characteristics

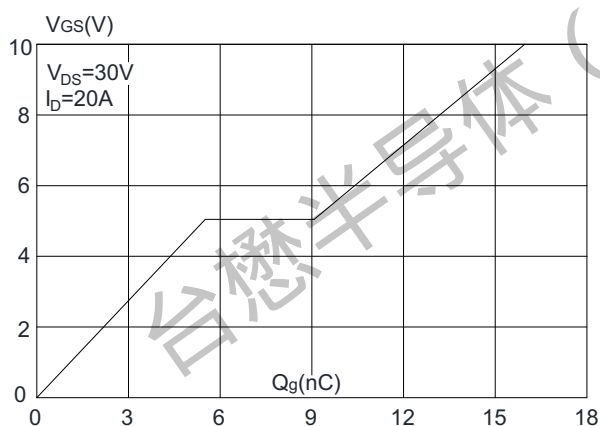
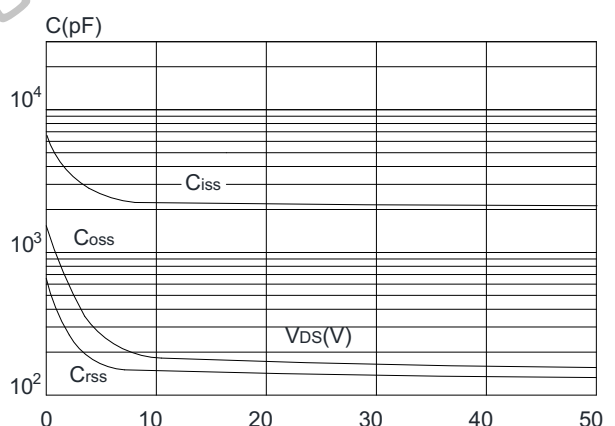

Figure 6: Capacitance Characteristics





TM60N06HAD

N-Channel Enhancement Mosfet

Figure 7: Normalized Breakdown Voltage vs. Junction Temperature

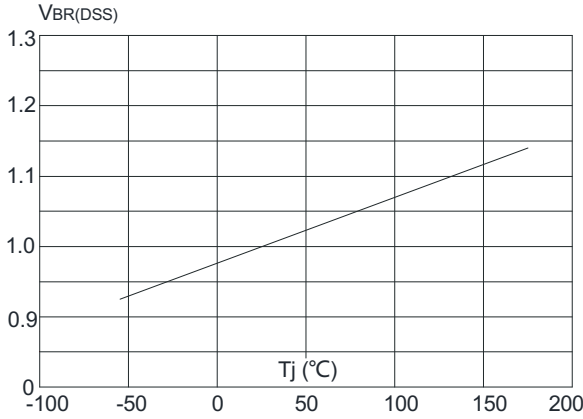

Figure 8: Normalized on Resistance vs. Junction Temperature

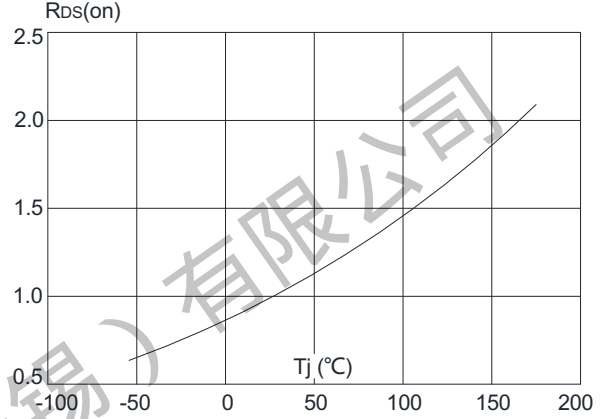

Figure 9: Maximum Safe Operating Area

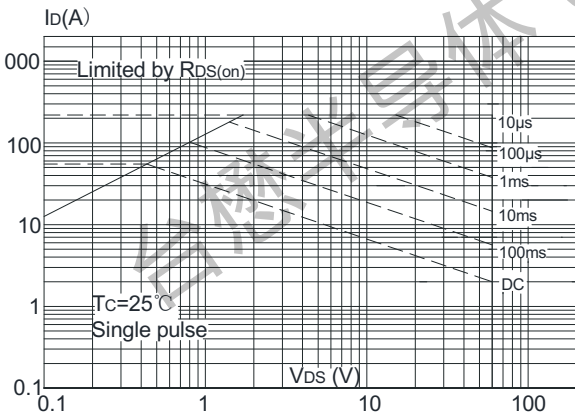

Figure 10: Maximum Continuous Drain Current vs. Case Temperature

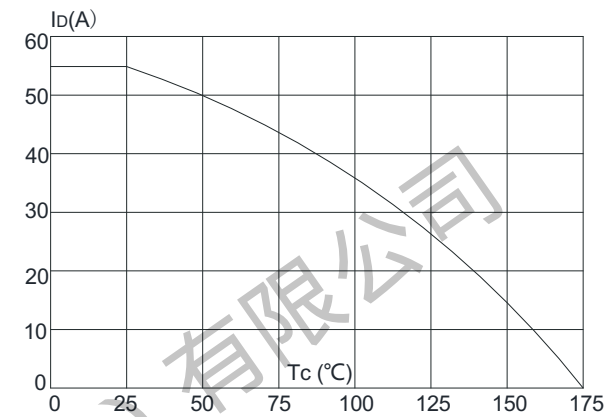
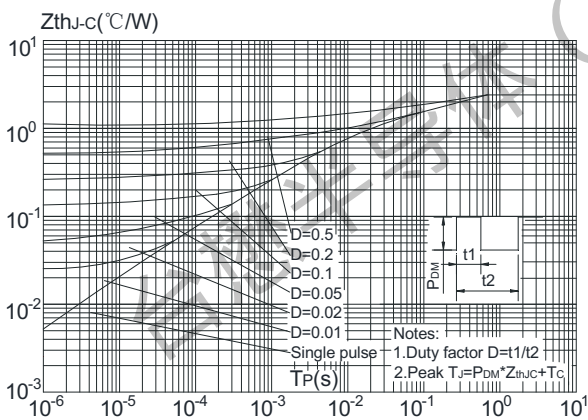

Figure.11: Maximum Effective Transient Thermal Impedance, Junction-to-Case



TM60N06HAD

N-Channel Enhancement Mosfet

Package Mechanical Data: TO-252-3L

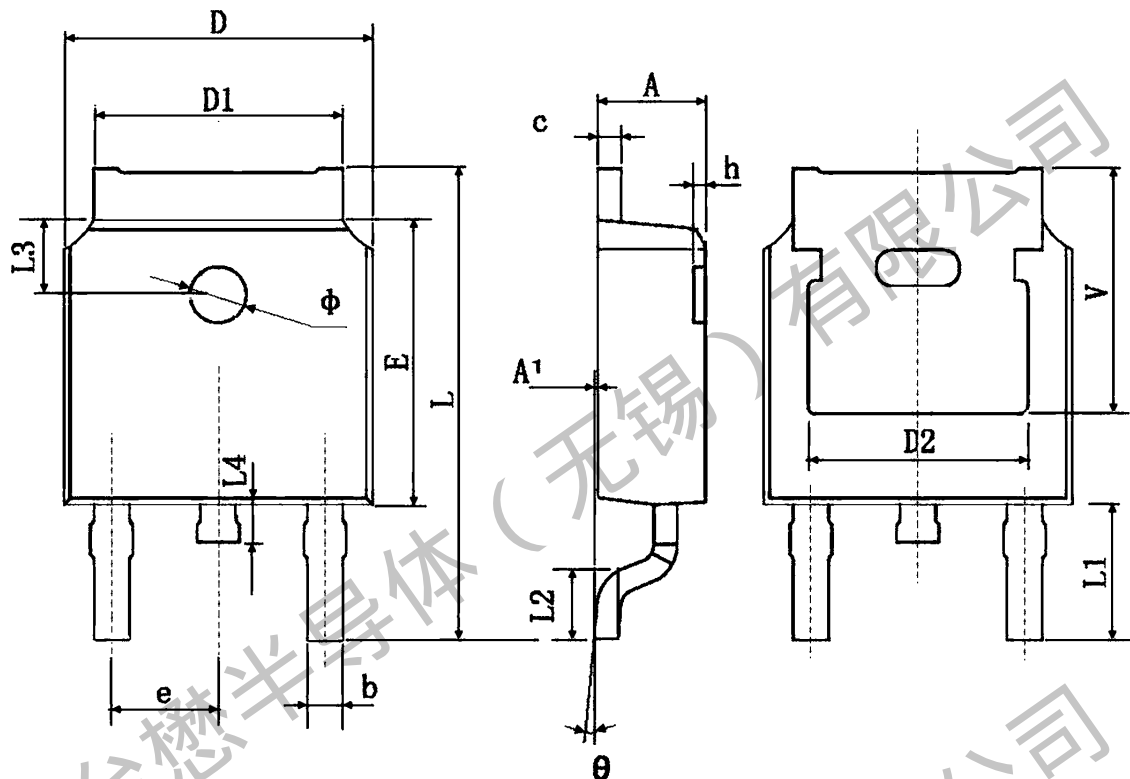

Symbol	Dimensions In Millimeters		Dimensions In Inches	
	Min.	Max.	Min.	Max.
A	2.200	2.400	0.087	0.094
A1	0.000	0.127	0.000	0.005
b	0.660	0.860	0.026	0.034
c	0.460	0.580	0.018	0.023
D	6.500	6.700	0.256	0.264
D1	5.100	5.460	0.201	0.215
D2	4.830 TYP.		0.190 TYP.	
E	6.000	6.200	0.236	0.244
e	2.186	2.386	0.086	0.094
L	9.800	10.400	0.386	0.409
L1	2.900 TYP.		0.114 TYP.	
L2	1.400	1.700	0.055	0.067
L3	1.600 TYP.		0.063 TYP.	
L4	0.600	1.000	0.024	0.039
φ	1.100	1.300	0.043	0.051
θ	0°	8°	0°	8°
h	0.000	0.300	0.000	0.012
V	5.350 TYP.		0.211 TYP.	



**TM60N06HAD**

**N-Channel Enhancement Mosfet**

TO-252-3L Embossed Carrier Tape

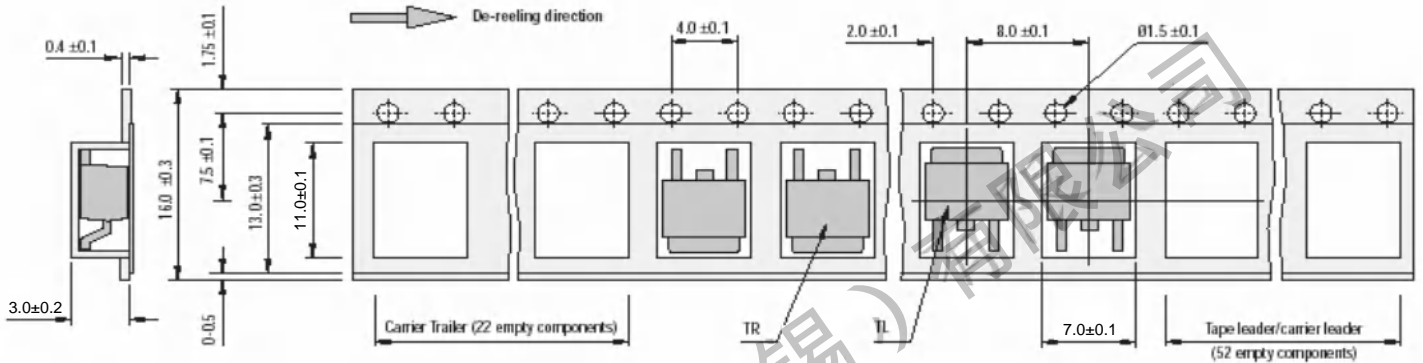

TO-252-3L Reel

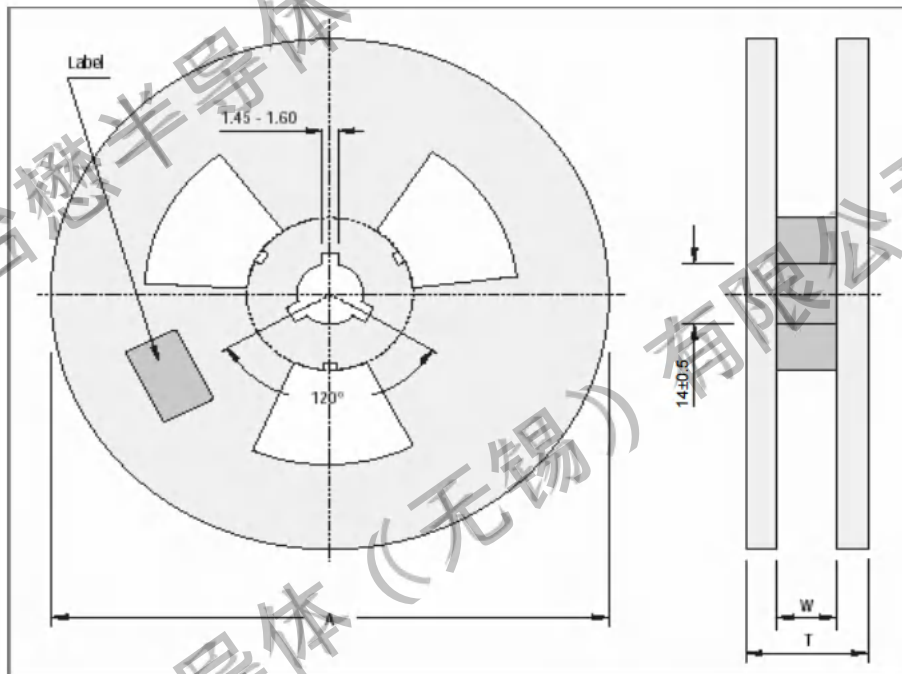

All Dimensions are in mm

Reel Specifications				
Package	Tape Width	Reel Dia. A - Max	Inside Thickness W	Reel Thickness T - max
TO-252-3L	16	330	18.0 ± 1.5	20

**Packaging Information**

REEL	Reel Size	Box	Box Size(mm)	Carton	Carton Size(mm)	G.W.(kg)
2,500 pcs	13 inch	5,000 pcs	355×370×50	25,000 pcs	380×275×380	



### Important Notices and Disclaimers

- Tritech-MOS Technology Corp.reserves the right to change thisdocument, its products, and specifications at any time without prior notice.
- Before final design, purchase, or use, customers should obtain and confirm the latest product information and specifications.
- Tritech-MOS Technology Corp. makes no warranties, representations or warranties regarding the suitability of its products for any specific purpose, and Tritech-MOS Technology Corp. does not assume any responsibility for application assistance or customer product design.
- Tritech-MOS Technology Corp. does not guarantee or assume any responsibility for the purchase or use of any unexpected or unauthorized products.
- Any intellectual property rights of Tritech-MOS Technology Corp. are not licensed through implicate or other means.
- Products of Tritech-MOS Technology Corp. are not included as critical components in life support equipment or systems without explicit written approval from Tritech-MOS Technology Corp.

Revision history:

Date	Rev	Description	Page
2023.11.05	23.11	Original	