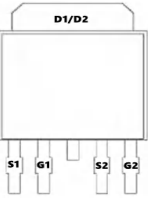
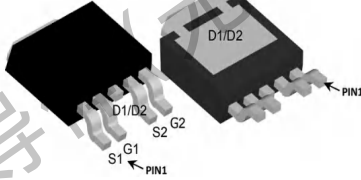
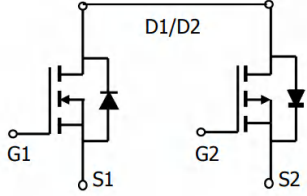

TM60G04GD

N+P-Channel Enhancement Mode Mosfet

<p>General Description</p> <ul style="list-style-type: none"> • Low $R_{DS(ON)}$ • RoHS and Halogen-Free Compliant <p>Applications</p> <ul style="list-style-type: none"> • Load switch • PWM 	<p>General Features</p> <p>N Channel $V_{DS} = 40V$ $I_D = 60A$ $R_{DS(ON)} = 4.2m\Omega$ (typ.) @ $V_{GS} = 10V$</p> <p>P Channel $V_{DS} = -40V$ $I_D = -48A$ $R_{DS(ON)} = 11m\Omega$ (typ.) @ $V_{GS} = -10V$</p> <p>100% UIS Tested 100% R_g Tested</p> 
--	---

GD:TO-252-4L

Marking: 60G04

Absolute Maximum Ratings ($T_C = 25^\circ C$ unless otherwise noted)

Symbol	Parameter	Rating		Units
		N-Ch	P-Ch	
V_{DS}	Drain-Source Voltage	40	-40	V
V_{GS}	Gate-Source Voltage	± 20	± 20	V
$I_D @ T_a = 25^\circ C$	Continuous Drain Current, $V_{GS} @ 10V$	60	-48	A
$I_D @ T_a = 100^\circ C$	Continuous Drain Current, $V_{GS} @ 10V$	40	-30	A
I_{DM}	Pulsed Drain Current	250	-220	A
$P_D @ T_C = 25^\circ C$	Total Power Dissipation	55	55	W
T_{STG}	Storage Temperature Range	-55 to 175	-55 to 175	$^\circ C$
T_J	Operating Junction Temperature Range	-55 to 175	-55 to 175	$^\circ C$

Thermal Data

Symbol	Parameter	Typ.	Max.	Unit
$R_{\theta JA}$	Thermal Resistance Junction-Ambient	---	48	$^\circ C/W$
$R_{\theta JC}$	Thermal Resistance Junction-Case	---	5	$^\circ C/W$



TM60G04GD

N+P-Channel Enhancement Mode Mosfet

N-CH Electrical Characteristics: ($T_C=25^\circ\text{C}$ unless otherwise noted)

Symbol	Parameter	Conditions	Min	Typ	Max	Units
Off Characteristics						
BV_{DSS}	Drain-Source Breakdown Voltage	$V_{GS}=0V, I_D=250\ \mu\text{A}$	40	---	---	V
I_{DSS}	Zero Gate Voltage Drain Current	$V_{GS}=0V, V_{DS}=-40V$	---	---	1	μA
I_{GSS}	Gate-Source Leakage Current	$V_{GS}=\pm 20V, V_{DS}=0A$	---	---	± 100	nA
On Characteristics						
$V_{GS(th)}$	GATE-Source Threshold Voltage	$V_{GS}=V_{DS}, I_D=250\ \mu\text{A}$	1.2	1.6	2.0	V
$R_{DS(on)}$	Drain-Source On Resistance	$V_{GS}=10V, I_D=20A$	---	4.2	5.2	m Ω
		$V_{GS}=4.5V, I_D=10A$	---	5.3	6.8	
G_{FS}	Forward Transconductance	$V_{DS}=10V, I_D=10A$	---	16	---	S
Dynamic Characteristics						
C_{iss}	Input Capacitance	$V_{DS}=25V, V_{GS}=0V, f=1\text{MHz}$	---	2380		pF
C_{oss}	Output Capacitance		---	230		
C_{rss}	Reverse Transfer Capacitance		---	148		
Switching Characteristics						
$t_{d(on)}$	Turn-On Delay Time	$V_{DD}=20V, I_D=1A,$ $R_{GEN}=3.3\ \Omega, V_{GS}=10V$	---	14.2	28	ns
t_r	Rise Time		---	18.3	36	ns
$t_{d(off)}$	Turn-Off Delay Time		---	38.8	76	ns
t_f	Fall Time		---	13.9	28	ns
Q_g	Total Gate Charge	$V_{GS}=4.5V, V_{DS}=32V,$ $I_D=10A$	---	25	50	nC
Q_{gs}	Gate-Source Charge		---	6.5	13	nC
Q_{gd}	Gate-Drain "Miller" Charge		---	12.1	24	nC
Drain-Source Diode Characteristics						
V_{SD}	Drain Diode Forward Voltage	$V_{GS}=0V, I_S=1A$	---	---	1	V
I_S	Continuous Source Current	$V_G=V_D=0V, \text{Force Current}$	---	---	60	A
I_{sm}	Pulsed Source Current		---	---	160	A

TM60G04GD

N+P-Channel Enhancement Mode Mosfet

Typical Characteristics

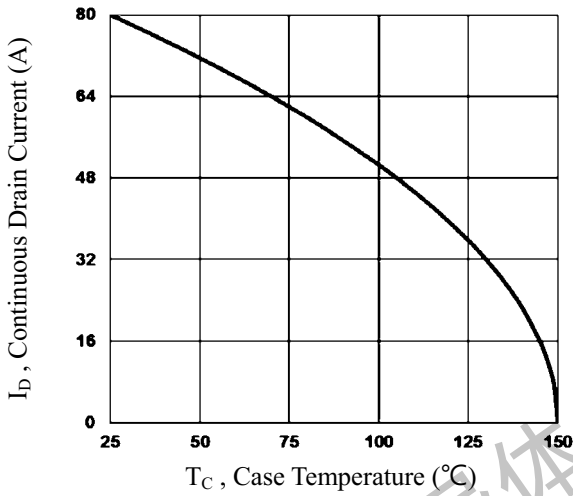

Fig.1 Continuous Drain Current vs. T_c

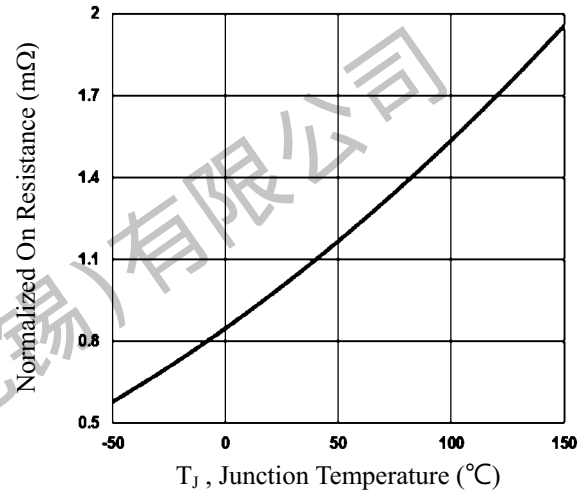

Fig.2 Normalized $R_{DS(on)}$ vs. T_j

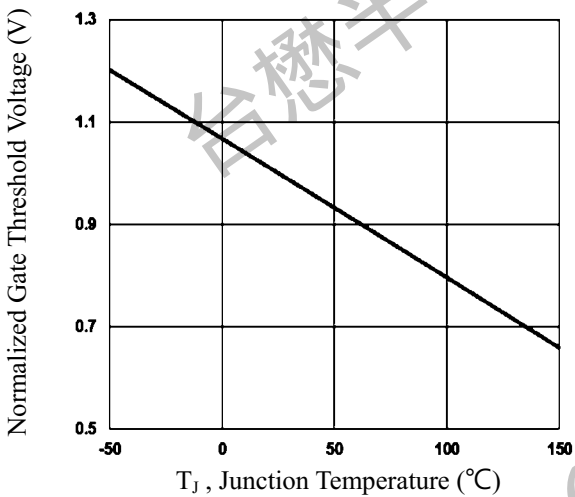

Fig.3 Normalized V_{th} vs. T_j

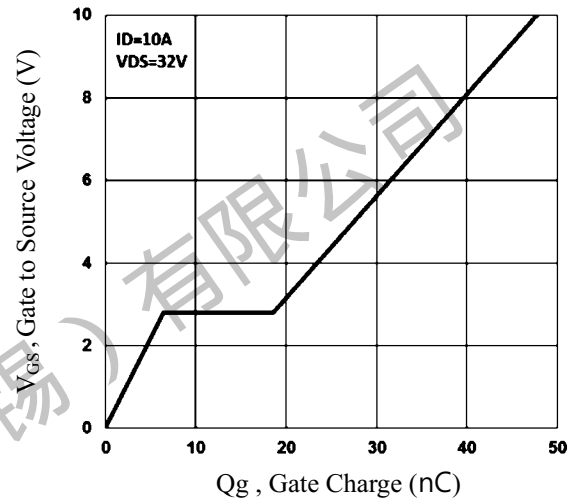

Fig.4 Gate Charge Waveform

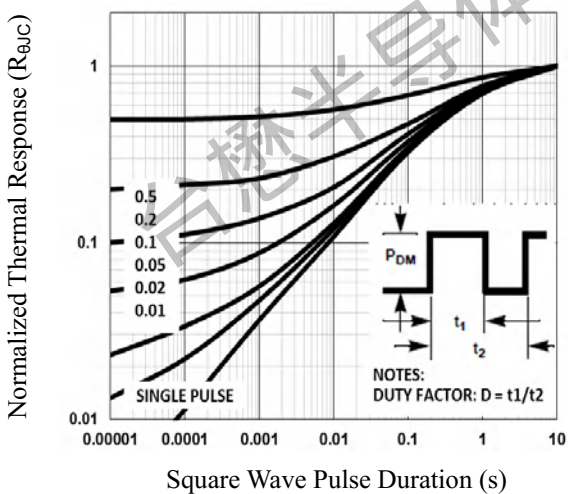

Fig.5 Normalized Transient Impedance

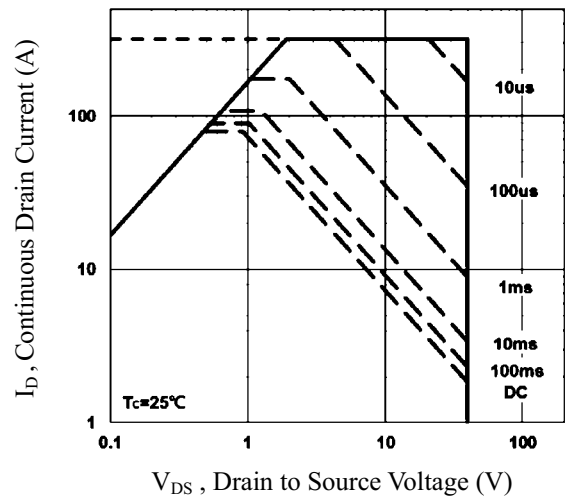

Fig.6 Maximum Safe Operation Area

TM60G04GD

N+P-Channel Enhancement Mode Mosfet

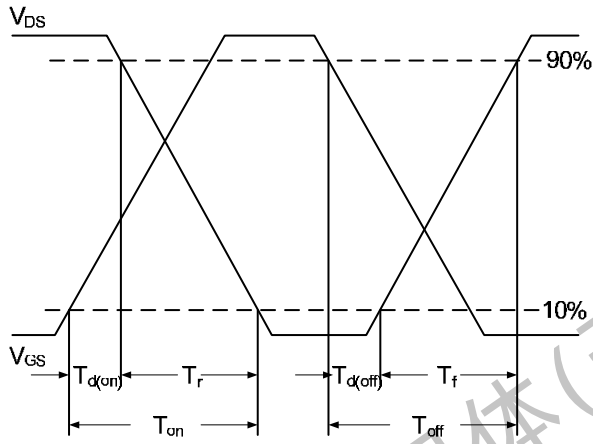

Fig.7 Switching Time Waveform

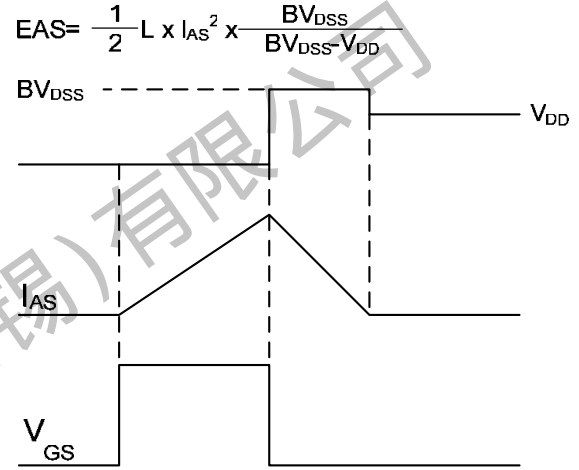

Fig.8 EAS Waveform



TM60G04GD

N+P-Channel Enhancement Mode Mosfet

P-CH Electrical Characteristics: ($T_c=25^\circ\text{C}$ unless otherwise noted)

Symbol	Parameter	Conditions	Min	Typ	Max	Units
Off Characteristics						
BV_{DSS}	Drain-Source Breakdown Voltage	$V_{GS}=0V, I_D=250\ \mu\text{A}$	-40	---	---	V
I_{DSS}	Zero Gate Voltage Drain Current	$V_{GS}=0V, V_{DS}=-40V, T_J=25^\circ\text{C}$	---	---	-1	μA
I_{GSS}	Gate-Source Leakage Current	$V_{GS}=\pm 20V, V_{DS}=0A$	---	---	± 100	nA
On Characteristics						
$V_{GS(th)}$	GATE-Source Threshold Voltage	$V_{GS}=V_{DS}, I_D=250\ \mu\text{A}$	-1	-1.75	-2.5	V
$R_{DS(on)}$	Drain-Source On Resistance	$V_{GS}=-10V, I_D=-10A$	---	11	14	m Ω
		$V_{GS}=-4.5V, I_D=-8A$	---	15	20	
G_{FS}	Forward Transconductance	$V_{DS}=-10V, I_D=-10A$	---	13	---	S
Dynamic Characteristics						
C_{iss}	Input Capacitance	$V_{DS}=-25V, V_{GS}=0V, f=1\text{MHz}$	---	2557	3800	pF
C_{oss}	Output Capacitance		---	220	320	
C_{rss}	Reverse Transfer Capacitance		---	127	180	
Switching Characteristics						
$t_{d(on)}$	Turn-On Delay Time	$V_{DD}=-20V, I_D=-1A,$ $R_G=6\ \Omega, V_{GS}=-10V$	---	23	40	ns
t_r	Rise Time		---	10	20	ns
$t_{d(off)}$	Turn-Off Delay Time		---	135	250	ns
t_f	Fall Time		---	46	90	ns
Q_g	Total Gate Charge		---	22.2	40	nC
Q_{gs}	Gate-Source Charge	$V_{GS}=-4.5V, V_{DS}=-32V,$	---	8.2	16	nC
Q_{gd}	Gate-Drain "Miller" Charge	$I_D=-10A$	---	8.8	16	nC
Drain-Source Diode Characteristics						
V_{SD}	Source Drain Diode Forward Voltage ²	$V_{GS}=0V, I_S=-1A, T_J=25^\circ\text{C}$	---	---	-1	V



TM60G04GD

N+P-Channel Enhancement Mode Mosfet

Typical Characteristics

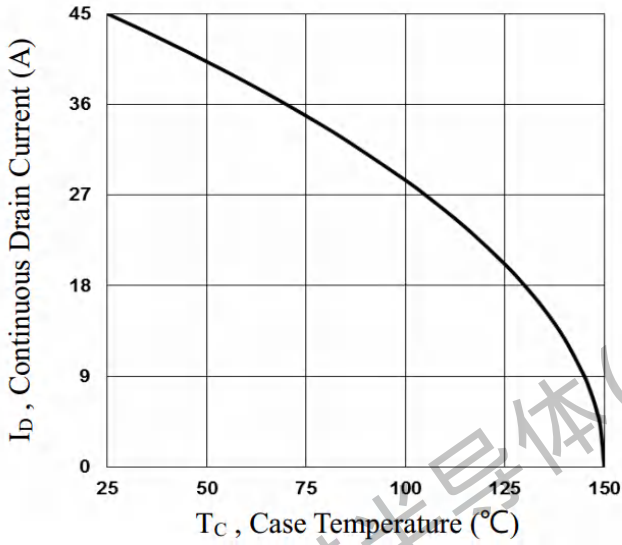

Fig.1 Continuous Drain Current vs. T_c

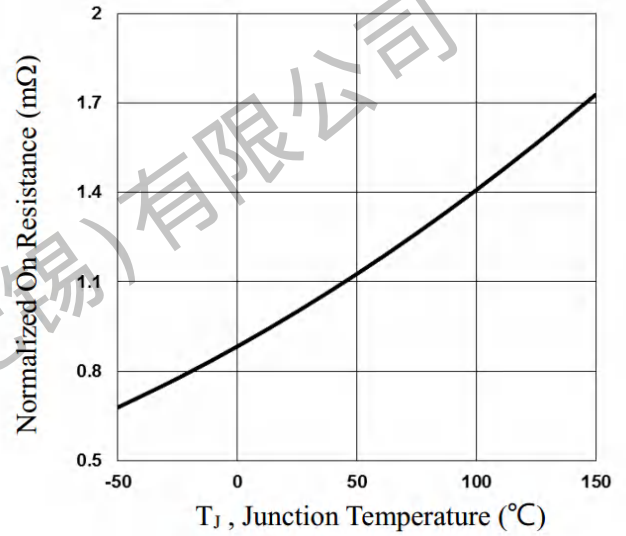

Fig.2 Normalized RDSON vs. T_j

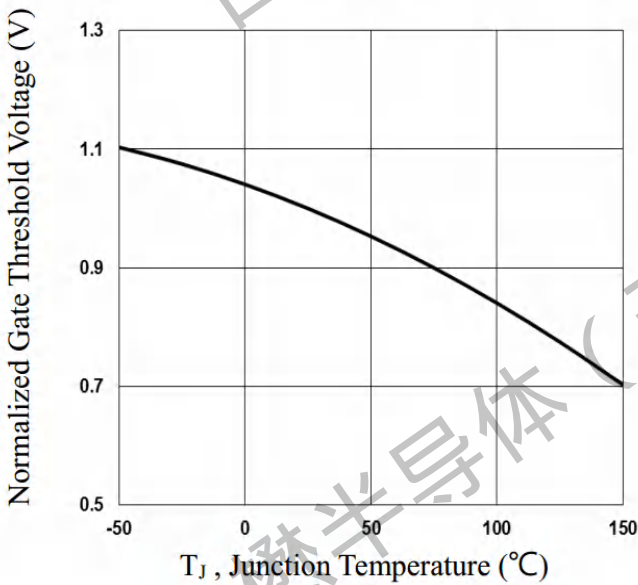

Fig.3 Normalized V_{th} vs. T_j

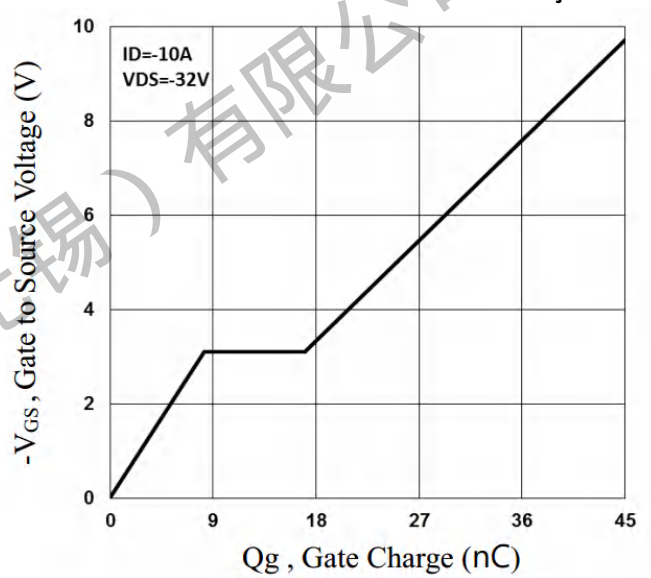

Fig.4 Gate Charge Waveform



TM60G04GD

N+P-Channel Enhancement Mode Mosfet

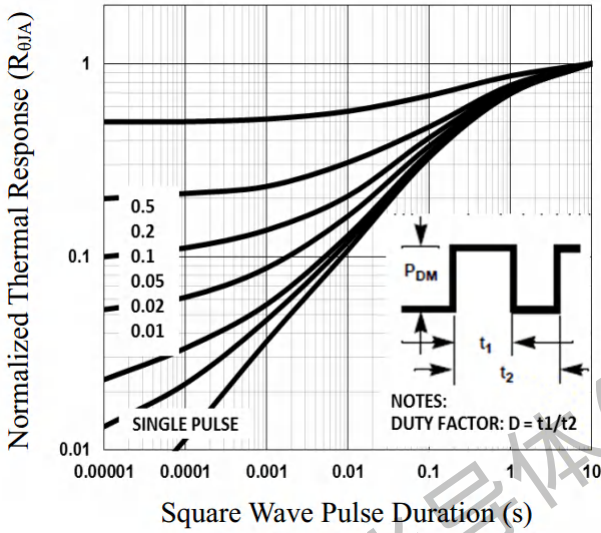

Fig.5 Normalized Transient Impedance

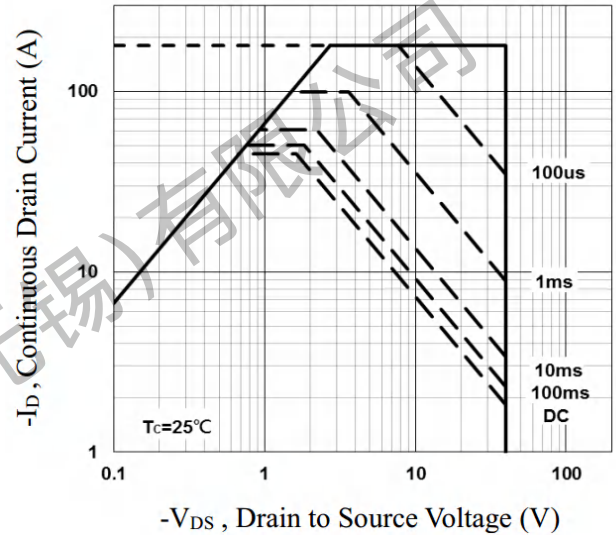

Fig.6 Maximum Safe Operation Area

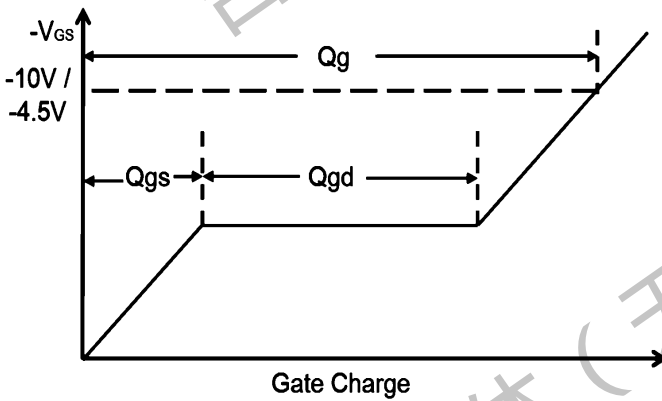

Fig.7 Switching Time Waveform

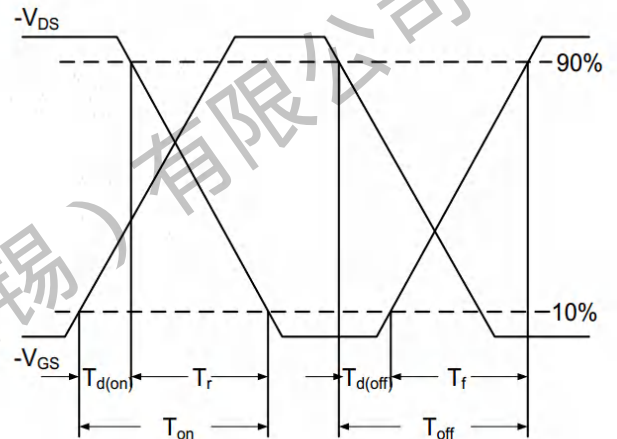
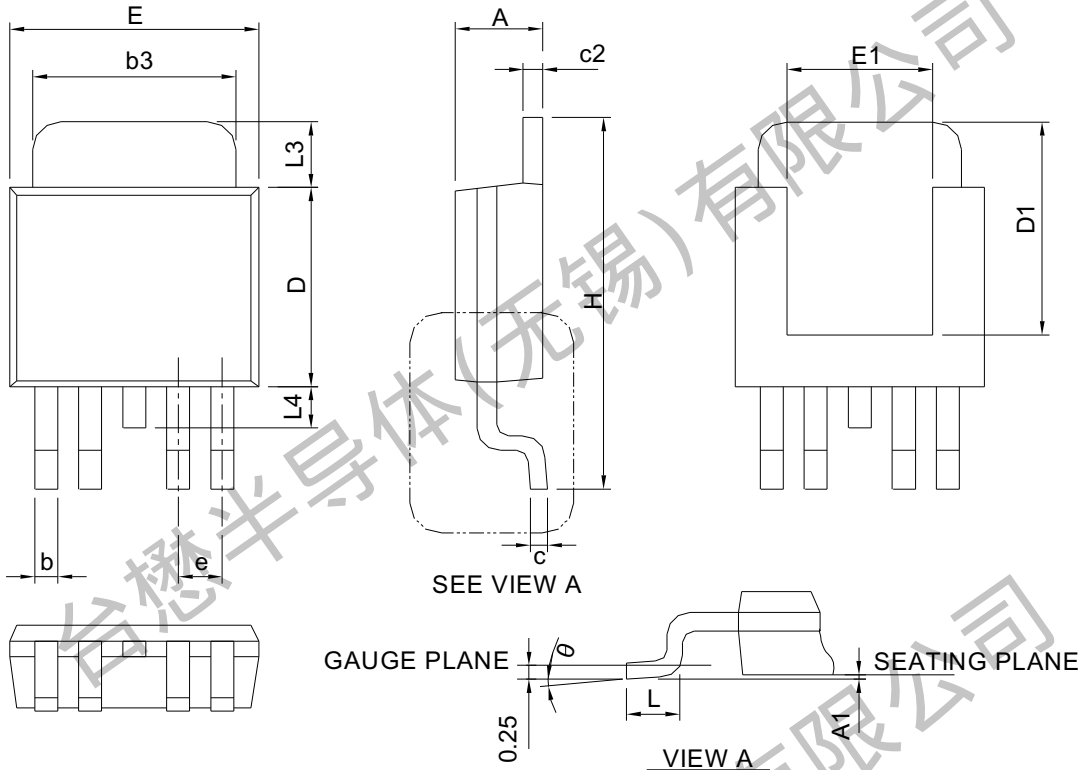

Fig.8 Gate Charge Waveform

TM60G04GD

N+P-Channel Enhancement Mode Mosfet

Package Mechanical Data:TO-252-4L



SYMBOL	TO-252-4			
	MILLIMETERS		INCHES	
	MIN.	MAX.	MIN.	MAX.
A	2.18	2.39	0.086	0.094
A1	-	0.2	-	0.008
b	0.50	0.71	0.020	0.028
b3	4.32	5.46	0.170	0.215
c	0.46	0.61	0.018	0.024
c2	0.46	0.89	0.018	0.035
D	5.33	6.22	0.210	0.245
D1	4.57	6.00	0.180	0.236
E	6.35	6.73	0.250	0.265
E1	3.81	6.00	0.150	0.236
e	1.30 BSC		0.051 BSC	
H	9.40	10.41	0.370	0.410
L	1.40	1.78	0.055	0.070
L3	0.89	2.03	0.035	0.080
L4	-	1.02	-	0.040
θ	0°	8°	0°	8°

RECOMMENDED LAND PATTERN

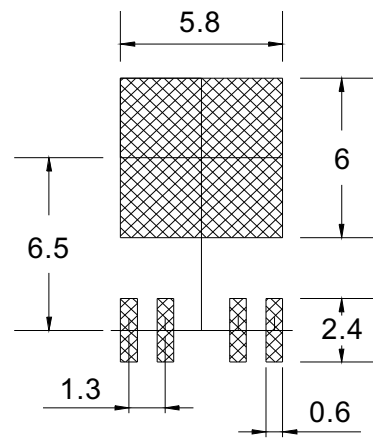

UNIT: mm

TM60G04GD

N+P-Channel Enhancement Mode Mosfet

TO-252-4L Embossed Carrier Tape

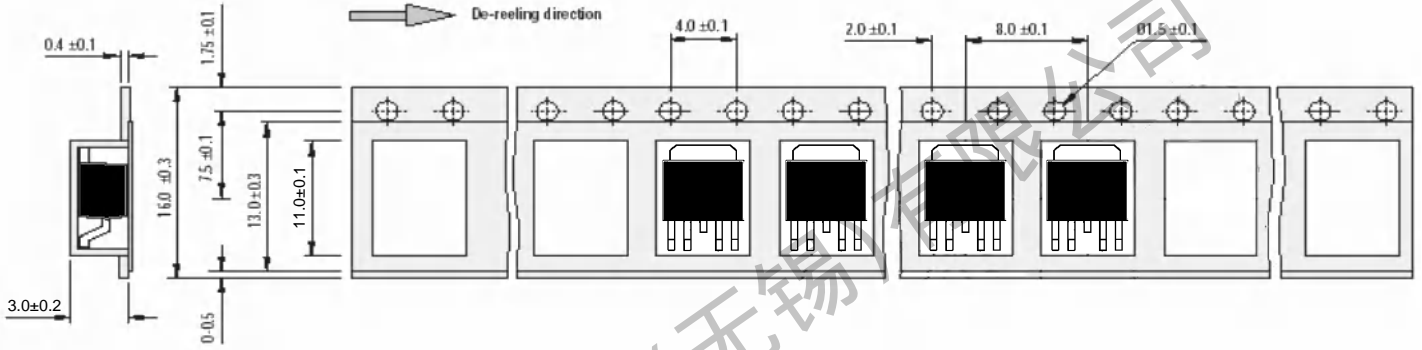

TO-252-4L Reel

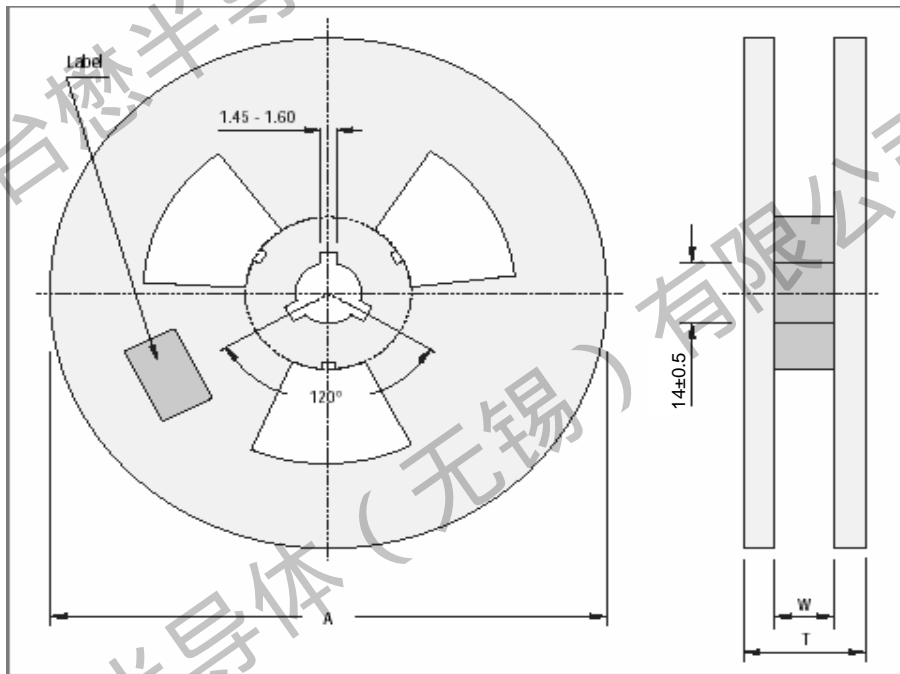

1.TO-252-4L Packaging

Package	Packing Form	Quantity		
		Reel	Inner Box	Outbox
TO-252-4L	Reel	2500	5	1

TM60G04GD

N+P-Channel Enhancement Mode Mosfet

Inner Box

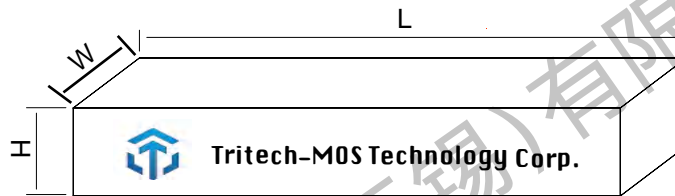

Dimension : 370 (L)×355(W) ×50(H) mm

Quantity : 2500 × 2Ea = 5000pcs

Outer Box

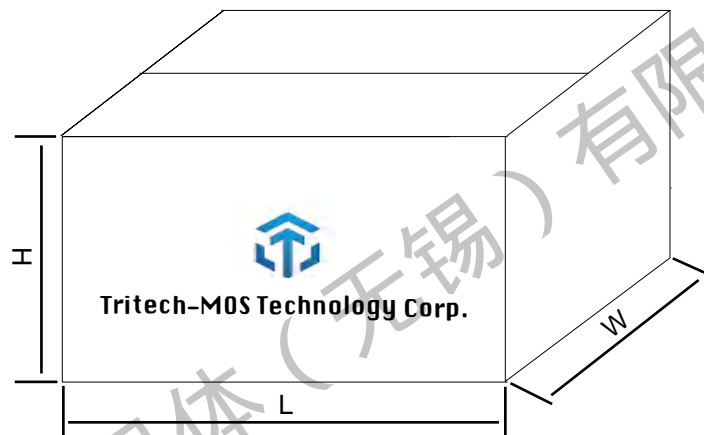

Dimension : 380(L)×380(W) ×275(H) mm

Quantity : 5000 × 5Ea = 25000pcs



TM60G04GD

N+P-Channel Enhancement Mode Mosfet

Important Notices and Disclaimers

- Tritech-MOS Technology Corp. reserves the right to change this document, its products, and specifications at any time without prior notice.
- Before final design, purchase, or use, customers should obtain and confirm the latest product information and specifications.
- Tritech-MOS Technology Corp. makes no warranties, representations or warranties regarding the suitability of its products for any specific purpose, and Tritech-MOS Technology Corp. does not assume any responsibility for application assistance or customer product design.
- Tritech-MOS Technology Corp. does not guarantee or assume any responsibility for the purchase or use of any unexpected or unauthorized products.
- Any intellectual property rights of Tritech-MOS Technology Corp. are not licensed through implicate or other means.
- Products of Tritech-MOS Technology Corp. are not included as critical components in life support equipment or systems without explicit written approval from Tritech-MOS Technology Corp.

Revision history:

Date	Rev	Description	Page
2023.09.21	23.09	Original	