



TM06N10DF

N-Channel Enhancement Mosfet

<p>General Description</p> <ul style="list-style-type: none"> • Low $R_{DS(ON)}$ • RoHS and Halogen-Free Compliant <p>Applications</p> <ul style="list-style-type: none"> • Load switch • PWM 	<p>General Features</p> <p>$V_{DS} = 100V$ $I_D = 6.0A$</p> <p>$R_{DS(ON)} = 110m\Omega(\text{typ.}) @ V_{GS} = 10V$</p> <p>100% UIS Tested 100% R_g Tested</p> 
--	--

DF:PDFN3x3-8L

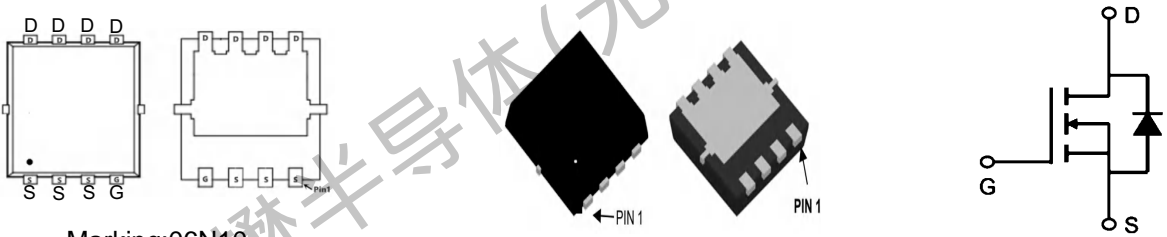

Marking:06N10

Absolute Maximum Ratings ($T_c=25^\circ\text{C}$ unless otherwise noted)

Symbol	Parameter	Rating	Units
V_{DS}	Drain-Source Voltage	100	V
V_{GS}	Gate-Source Voltage	± 20	V
$I_D @ T_c=25^\circ\text{C}$	Continuous Drain Current, $V_{GS} @ 10V$	6.0	A
$I_D @ T_c=100^\circ\text{C}$	Continuous Drain Current, $V_{GS} @ 10V$	3.9	A
I_{DM}	Pulsed Drain Current	37.3	A
$P_D @ T_c=25^\circ\text{C}$	Total Power Dissipation	3.5	W
T_{STG}	Storage Temperature Range	-55 to 150	$^\circ\text{C}$
T_J	Operating Junction Temperature Range	-55 to 150	$^\circ\text{C}$

Thermal Data

Symbol	Parameter	Typ.	Max.	Unit
$R_{\theta JA}$	Thermal Resistance Junction-Ambient	---	62	$^\circ\text{C}/\text{W}$
$R_{\theta JC}$	Thermal Resistance Junction-Case	---	3.6	$^\circ\text{C}/\text{W}$



TM06N10DF

N-Channel Enhancement Mosfet

Electrical Characteristics: ($T_C=25^\circ\text{C}$ unless otherwise noted)

Symbol	Parameter	Conditions	Min	Typ	Max	Units
Off Characteristics						
BV_{DSS}	Drain-Source Breakdown Voltage	$V_{GS}=0V, I_D=250 \mu A$	100	---	---	V
I_{DSS}	Drain-Source Leakage Current	$V_{GS}=0V, V_{DS}=80V, T_J=25^\circ\text{C}$	---	---	1	μA
		$V_{GS}=0V, V_{DS}=80V, T_J=55^\circ\text{C}$	---	---	10	μA
I_{GSS}	Gate-Source Leakage Current	$V_{GS}=\pm 20V, V_{DS}=0A$	---	---	± 100	nA
On Characteristics						
$V_{GS(th)}$	GATE-Source Threshold Voltage	$V_{GS}=V_{DS}, I_D=250 \mu A$	1	2	3	V
$R_{DS(on)}$	Drain-Source On Resistance ³	$V_{GS}=10V, I_D=3.2A$	---	110	120	$m \Omega$
		$V_{GS}=4.5V, I_D=2.6A$	---	---	---	
G_{FS}	Forward Transconductance	$V_{DS}=15V, I_D=3.2A$	---	8	---	S
Dynamic Characteristics						
C_{iss}	Input Capacitance	$V_{DS}=15V, V_{GS}=0V, f=1\text{MHz}$	---	1514	---	pF
C_{oss}	Output Capacitance		---	56	---	
C_{rss}	Reverse Transfer Capacitance		---	54	---	
Switching Characteristics						
$t_{d(on)}$	Turn-On Delay Time ^{3,4}	$V_{DS} = 50 V, R_L = 15.7 \Omega$ $I_D = 3.2 A,$ $V_{GEN} = 10 V, R_{GEN} = 6 \Omega$	---	7	---	ns
t_r	Rise Time ^{3,4}		---	5	---	ns
$t_{d(off)}$	Turn-Off Delay Time ^{3,4}		---	31	---	ns
t_f	Fall Time ^{3,4}		---	7	---	ns
Q_g	Total Gate Charge ^{3,4}		---	8.8	---	nC
Q_{gs}	Gate-Source Charge ^{3,4}	$V_{DS}=50V, V_{GS}=4.5V,$ $I_D=3.2A$	---	3.4	---	nC
Q_{gd}	Gate-Drain "Miller" Charge ^{3,4}		---	2.9	---	nC
Drain-Source Diode Characteristics						
V_{SD}	Source-Drain Diode Forward Voltage ²	$V_{GS}=0V, I_S=2.3A, T_J=25^\circ\text{C}$	---	0.81	---	V



TM06N10DF

N-Channel Enhancement Mosfet

Typical Characteristics

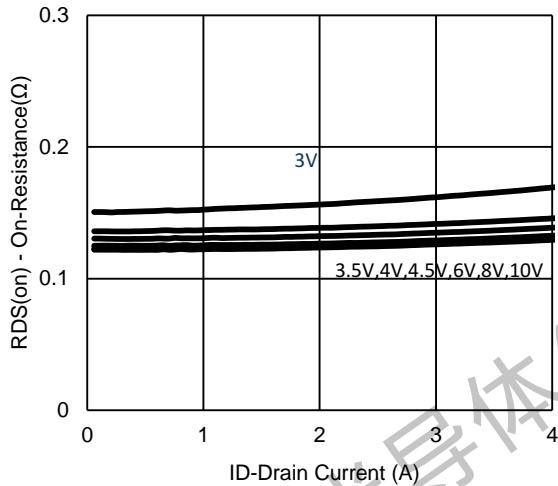

1. On-Resistance vs. Drain Current

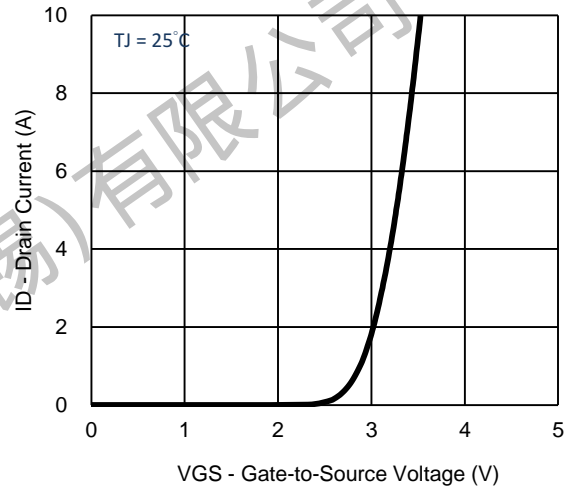

2. Transfer Characteristics

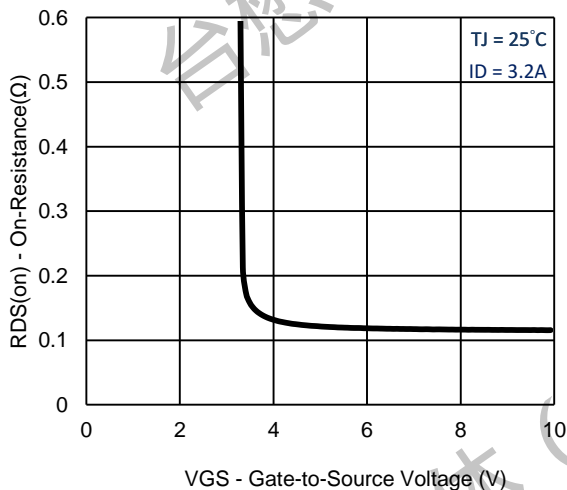

3. On-Resistance vs. Gate-Source Voltage

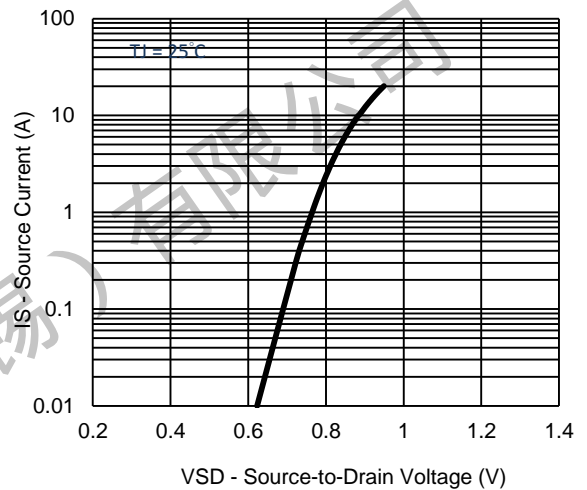

4. Drain-to-Source Forward Voltage

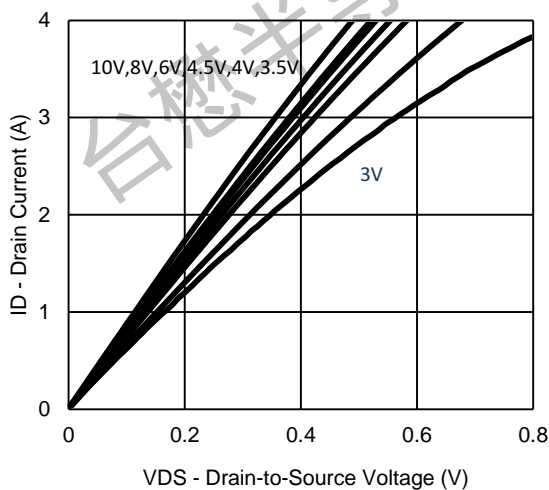

5. Output Characteristics

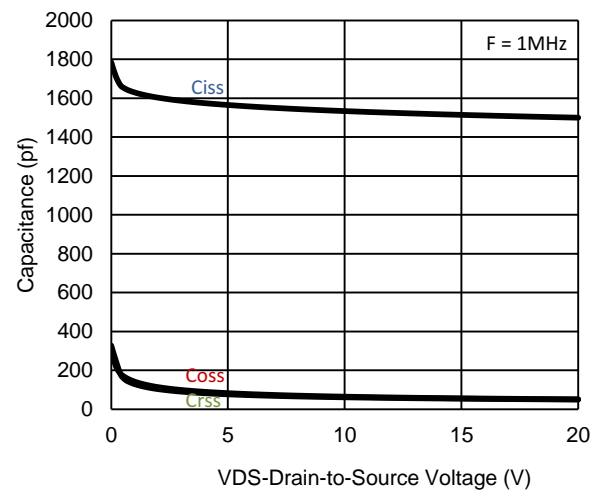

6. Capacitance



TM06N10DF

N-Channel Enhancement Mosfet

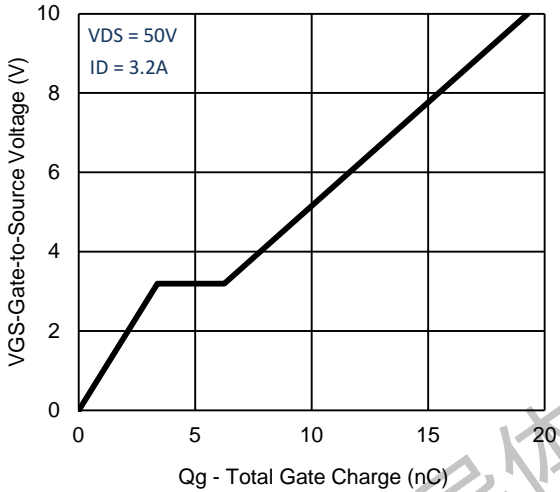

7. Gate Charge

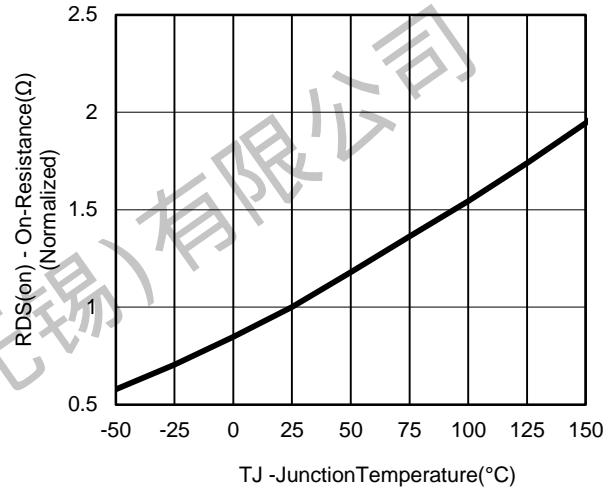

8. Normalized On-Resistance Vs Junction Temperature

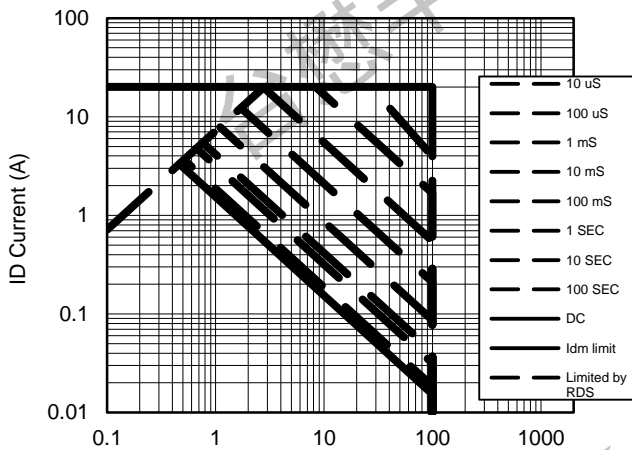

9. Safe Operating Area

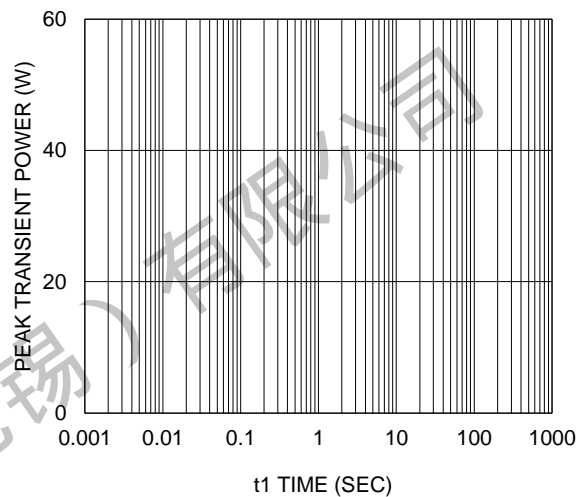

10. Single Pulse Maximum Power Dissipation

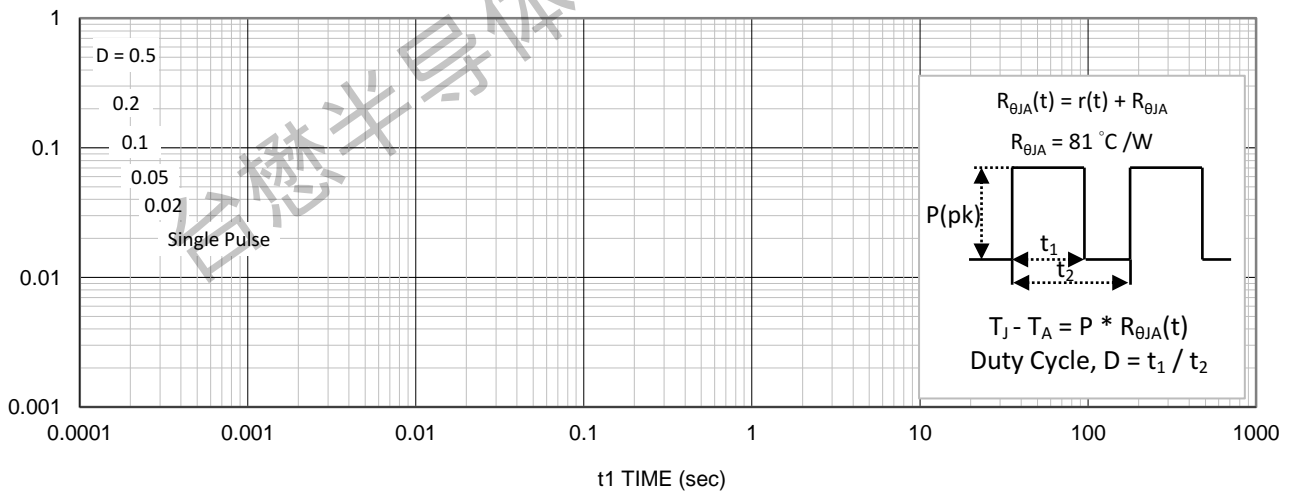

11. Normalized Thermal Transient Junction to Ambient



TM06N10DF

N-Channel Enhancement Mosfet

Package Mechanical Data:DFN3x3-8L

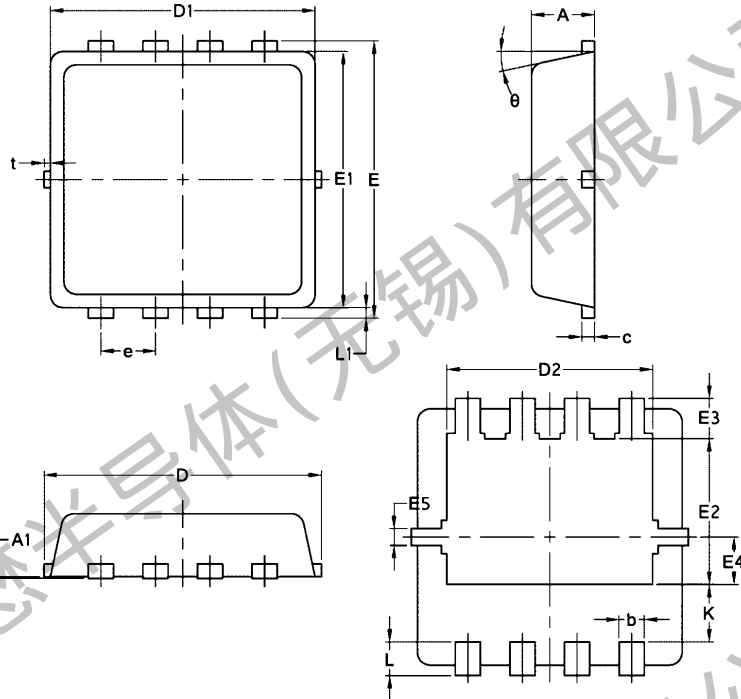

Symbol	Common		
	mm		
	Mim	Nom	Max
A	0.70	0.75	0.85
A1	/	/	0.05
b	0.20	0.30	0.40
c	0.10	0.152	0.25
D	3.15	3.30	3.45
D1	3.00	3.15	3.25
D2	2.29	2.45	2.65
E	3.15	3.30	3.45
E1	2.90	3.05	3.20
E2	1.54	1.74	1.94
E3	0.28	0.48	0.65
E4	0.37	0.57	0.77
E5	0.10	0.20	0.30
e	0.60	0.65	0.70
K	0.59	0.69	0.89
L	0.30	0.40	0.50
L1	0.06	0.125	0.20
t	0	0.075	0.13
Φ	10	12	14

TM06N10DF

N-Channel Enhancement Mosfet

PDFN3x3-8L Embossed Carrier Tape

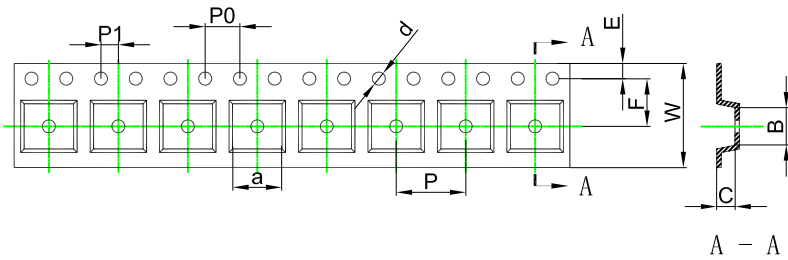

Packaging Description:

SOP-8L parts are shipped in tape. The carrier tape is made from a dissipative (carbon filled) polycarbonate resin. The cover tape is a multilayer film (Heat Activated Adhesive in nature) primarily composed of polyester film, adhesive layer, sealant, and anti-static sprayed agent. These reeled parts in standard option are shipped with 2,500 units per 13" or 33cm diameter reel. The reels are clear in color and is made of polystyrene plastic (anti-static coated).

ALL DIM IN mm

Dimensions are in millimeter										
Pkg type	a	B	C	d	E	F	P0	P	P1	W
PDFN3x3-8L	6.40	5.40	2.10	Ø1.50	1.75	5.50	4.00	8.00	2.00	12.00

PDFN3x3-8L Tape Leader and Trailer

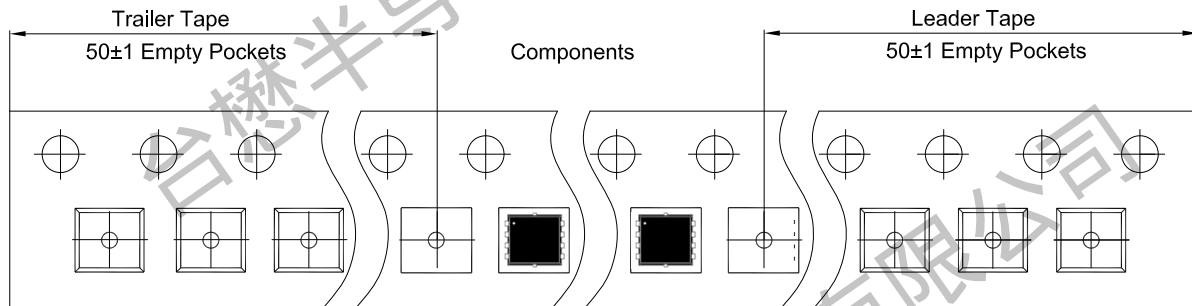

PDFN3x3-8L Reel

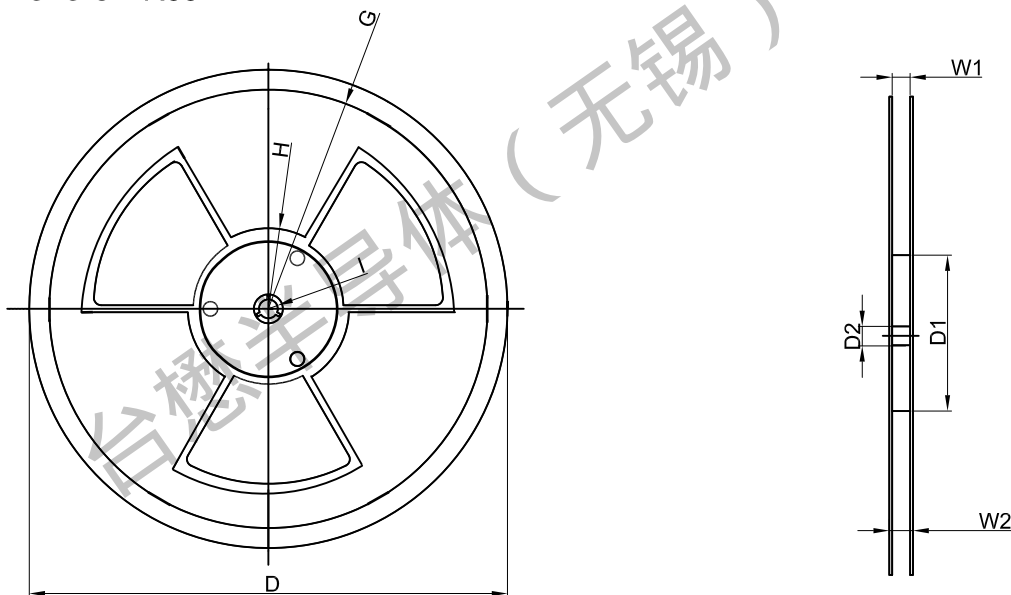

Dimensions are in millimeter								
Reel Option	D	D1	D2	G	H	I	W1	W2
13" Dia	Ø330.00	100.00	13.00	R135.00	R55.00	R6.50	12.00	14.00

REEL	Reel Size	Box	Box Size(mm)	Carton	Carton Size(mm)	G.W.(kg)
5,000 pcs	13 inch	10,000 pcs	370×355×52	50,000 pcs	400×360×368	

Important Notices and Disclaimers

- Tritech-MOS Technology Corp. reserves the right to change this document, its products, and specifications at any time without prior notice.
- Before final design, purchase, or use, customers should obtain and confirm the latest product information and specifications.
- Tritech-MOS Technology Corp. makes no warranties, representations or warranties regarding the suitability of its products for any specific purpose, and Tritech-MOS Technology Corp. does not assume any responsibility for application assistance or customer product design.
- Tritech-MOS Technology Corp. does not guarantee or assume any responsibility for the purchase or use of any unexpected or unauthorized products.
- Any intellectual property rights of Tritech-MOS Technology Corp. are not licensed through implicate or other means.
- Products of Tritech-MOS Technology Corp. are not included as critical components in life support equipment or systems without explicit written approval from Tritech-MOS Technology Corp.

Revision history:

Date	Rev	Description	Page
2024.05.14	24.05	Original	