



TM03N10AI

N-Channel Enhancement Mosfet

<p>General Description</p> <ul style="list-style-type: none"> • Low $R_{DS(ON)}$ • RoHS and Halogen-Free Compliant <p>Applications</p> <ul style="list-style-type: none"> • Load switch • PWM 	<p>General Features</p> <p>$V_{DS} = 100V$ $I_D = 3A$ $R_{DS(ON)} = 200m\Omega(\text{typ.}) @ V_{GS} = 10V$</p> <p>100% UIS Tested 100% R_g Tested</p> 
--	---

I: SOT-23

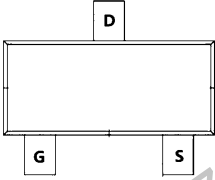
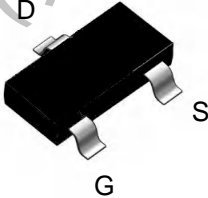
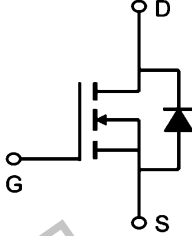
Marking: 1002 OR MA4

Absolute Maximum Ratings ($T_C=25^\circ\text{C}$ unless otherwise noted)

Symbol	Parameter	Rating	Units
V_{DS}	Drain-Source Voltage	100	V
V_{GS}	Gate-Source Voltage	± 20	V
$I_D @ T_A=25^\circ\text{C}$	Continuous Drain Current, $V_{GS} @ 10V^1$	3	A
$I_D @ T_A=70^\circ\text{C}$	Continuous Drain Current, $V_{GS} @ 10V^1$	1.7	A
I_{DM}	Pulsed Drain Current ²	8.8	A
$P_D @ T_A=25^\circ\text{C}$	Total Power Dissipation ³	1	W
T_{STG}	Storage Temperature Range	-55 to 175	$^\circ\text{C}$
T_J	Operating Junction Temperature Range	-55 to 175	$^\circ\text{C}$

Thermal Data

Symbol	Parameter	Typ.	Max.	Unit
$R_{\theta JA}$	Thermal Resistance Junction-ambient ¹	---	162	$^\circ\text{C/W}$
R_{JC}	Thermal Resistance Junction Case ¹	---	---	$^\circ\text{C/W}$

TM03N10AI

N-Channel Enhancement Mosfet

Electrical Characteristics (T_J=25°C unless otherwise specified)

Parameter	Symbol	Test Condition	Min.	Typ.	Max.	Unit
Static Characteristics						
Drain-Source Breakdown Voltage	V _{(BR)DSS}	V _{GS} = 0 V, I _D = 250μA	100	-	-	V
Gate Leakage Current	I _{GSS}	V _{GS} = ±20V, V _{DS} = 0V	-	-	±100	nA
Drain Cut-off Current	I _{DSS}	V _{DS} = 100V, V _{GS} = 0V	-	-	1	μA
Gate Threshold Voltage	V _{GS(th)}	V _{GS} = V _{DS} , I _D = 250μA	1.0	2.0	3.0	V
Drain-Source on-state Resistance ³	R _{DS(on)}	V _{GS} = 10V, I _D = 2A	-	200	230	mΩ
		V _{GS} = 4.5V, I _D = 1.5A	-	---	---	
Dynamic Characteristics⁴						
Input Capacitance	C _{iss}	V _{GS} = 0V, V _{DS} = 50V, f = 1MHz	-	440	-	pF
Output Capacitance	C _{oss}		-	14	-	
Reverse Transfer Capacitance	C _{rss}		-	10	-	
Switching Characteristics⁴						
Total gate charge	Q _g	V _{GS} = 10V, V _{DS} = 50V, I _D = 2A	-	5.3	-	nC
Gate-source charge	Q _{gs}		-	1.4	-	
Gate-drain charge	Q _{gd}		-	1.8	-	
Turn-on Time	t _{d(on)}	V _{GS} = 10V, V _{DD} = 50V, R _G = 1Ω, I _D = 2A	-	14	-	ns
Rise time	t _r		-	54	-	
Turn-off Time	t _{d(off)}		-	18	-	
Fall time	t _f		-	11	-	
Source-Drain Diode characteristics						
Body Diode Voltage ³	V _{SD}	I _S = 1A, V _{GS} = 0V	-	-	1.2	V
Continuous Source Current	I _S		-	-	3	A

Notes:

1. Repetitive rating, pulse width limited by junction temperature T_{J(MAX)}=150°C.
2. The data tested by surface mounted on a 1 inch² FR-4 board with 2OZ copper, The value in any given application depends on the user's specific board design.
3. Pulse Test: Pulse width≤300μs, duty cycle≤2%.
4. This value is guaranteed by design hence it is not included in the production test.

TM03N10AI

N-Channel Enhancement Mosfet

Typical Characteristics

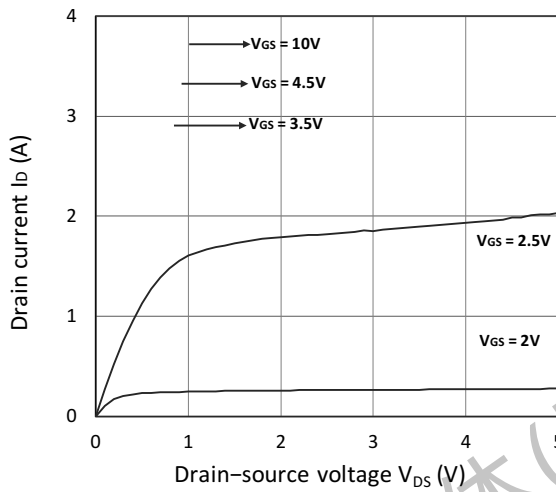

Figure 1. Output Characteristics

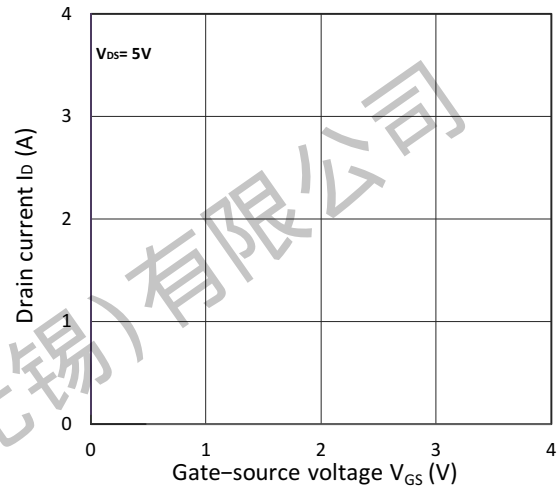

Figure 2. Transfer Characteristics

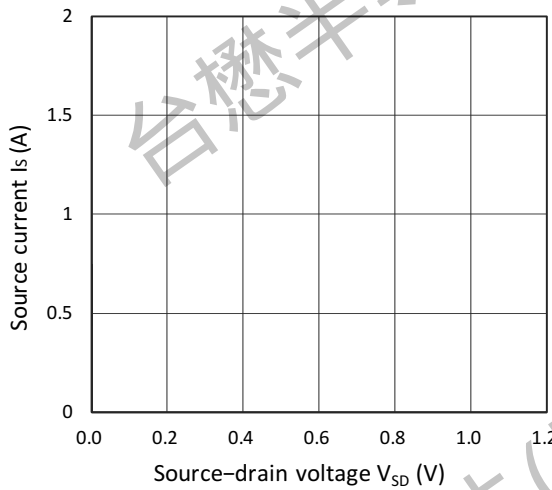

Figure 3. Forward Characteristics of Reverse

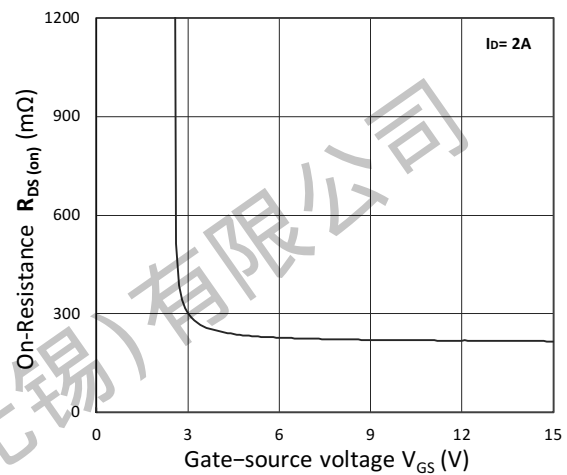

Figure 4. $R_{DS(on)}$ vs. V_{GS}

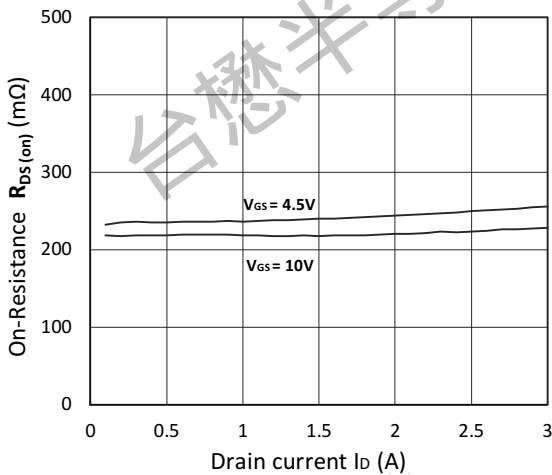

Figure 5. $R_{DS(on)}$ vs. I_D

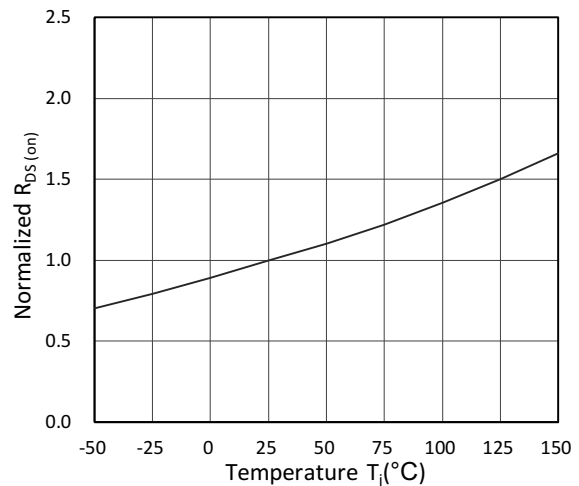

Figure 6. Normalized $R_{DS(on)}$ vs. Temperature

TM03N10AI

N-Channel Enhancement Mosfet

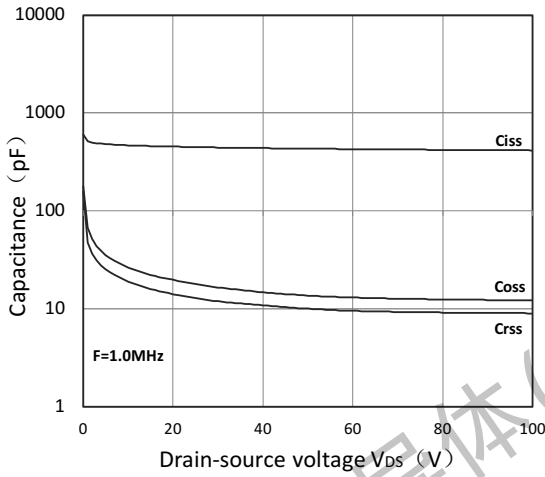

Figure 7. Capacitance Characteristics

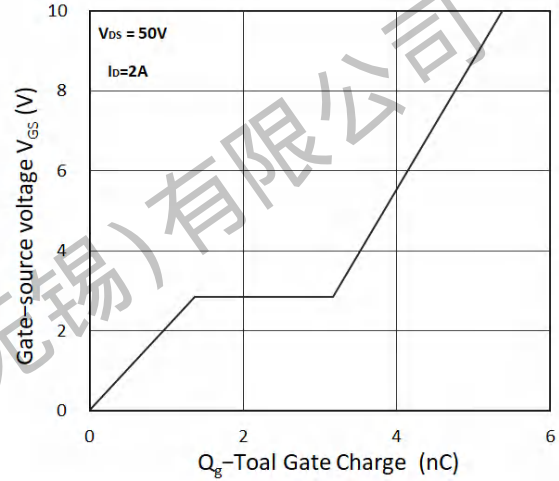

Figure 8. Gate Charge Characteristics



TM03N10AI

N-Channel Enhancement Mosfet

Package Mechanical Data:SOT-23

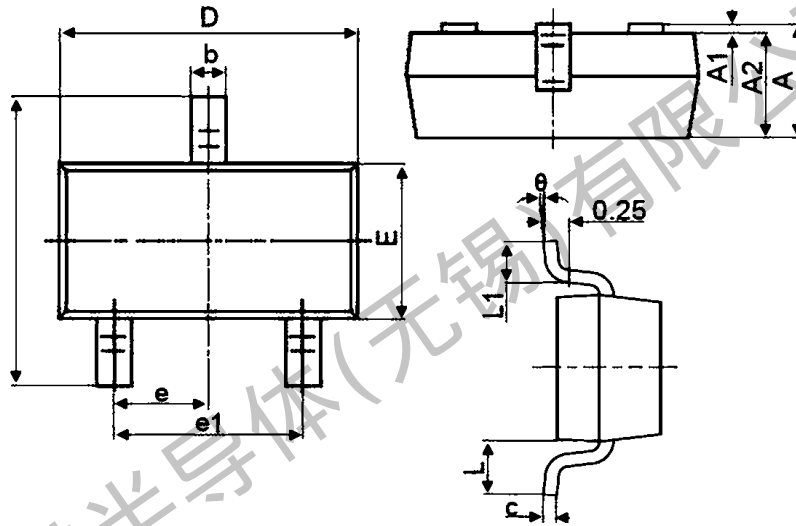

Symbol	Dimensions in Millimeters	
	MIN.	MAX.
A	0.900	1.150
A1	0.000	0.100
A2	0.900	1.050
b	0.300	0.500
c	0.080	0.150
D	2.800	3.000
E	1.200	1.400
E1	2.250	2.550
e	0.950TYP	
e1	1.800	2.000
L	0.550REF	
L1	0.300	0.500
theta	0°	8°



TM03N10AI

N-Channel Enhancement Mosfet

SOT-23 Packing

1. The method of packaging and dimension are shown as below figure. (Dimension in mm)

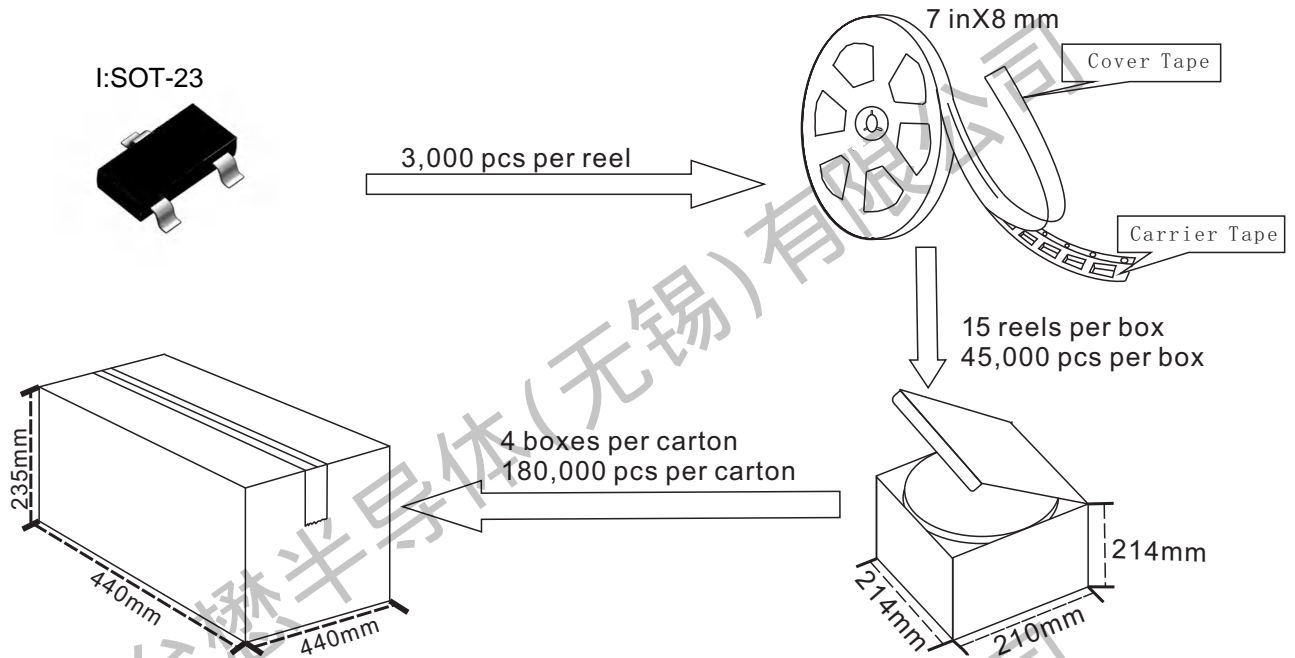

SOT-23 Embossed Carrier Tape

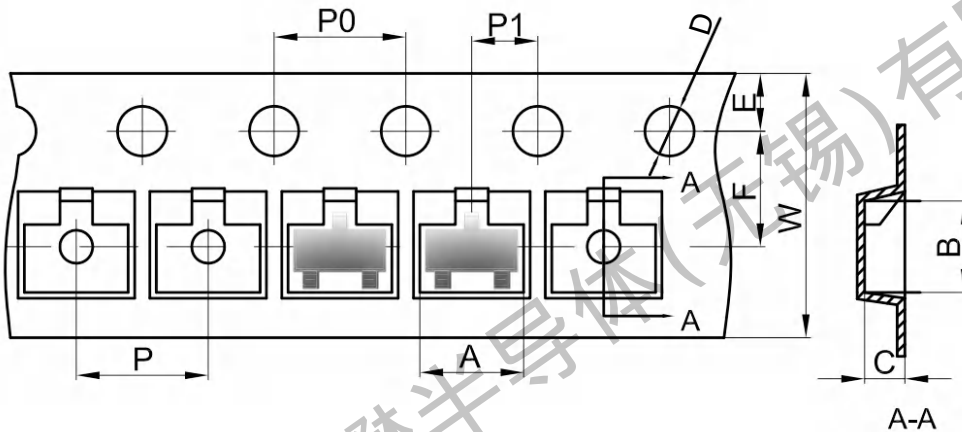

Dimensions are in millimeter

Pkg type	A	B	C	D	E	F	P0	P	P1	W
SOT-23	3.15	2.77	1.22	Ø1.50	1.75	3.50	4.00	4.00	2.00	8.00

SOT-23 Tape Leader and Trailer

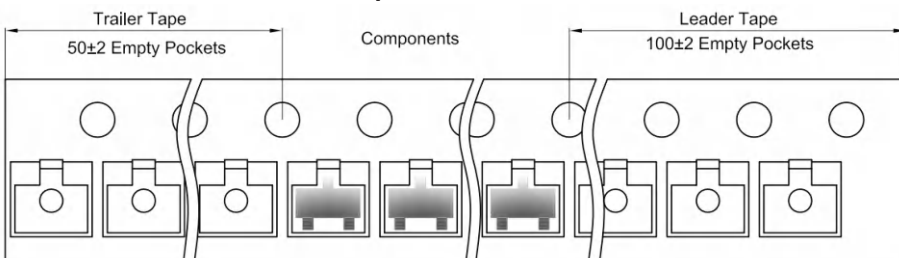



Important Notices and Disclaimers

- Tritech-MOS Technology Corp. reserves the right to change this document, its products, and specifications at any time without prior notice.
- Before final design, purchase, or use, customers should obtain and confirm the latest product information and specifications.
- Tritech-MOS Technology Corp. makes no warranties, representations or warranties regarding the suitability of its products for any specific purpose, and Tritech-MOS Technology Corp. does not assume any responsibility for application assistance or customer product design.
- Tritech-MOS Technology Corp. does not guarantee or assume any responsibility for the purchase or use of any unexpected or unauthorized products.
- Any intellectual property rights of Tritech-MOS Technology Corp. are not licensed through implicate or other means.
- Products of Tritech-MOS Technology Corp. are not included as critical components in life support equipment or systems without explicit written approval from Tritech-MOS Technology Corp.

Revision history:

Date	Rev	Description	Page
2023.04.04	23.04	Original	